



Interessenverband  
**Netzipedanz**



HOCHSCHULE RUHR WEST  
UNIVERSITY OF APPLIED SCIENCES

# **Measurement and Analysis of Disturbances induced by Electric Vehicles – A Case Study**

November 2<sup>nd</sup>, 2021

Jan-Philipp Kitzig and

Gerd Bumiller

Hochschule Ruhr West, University of Applied Sciences

# Outline

- Revisit: Harmonic Power Flow Measurements with PQMS
- The Case
- Measurement Setup
- Measurements
- Conclusion

# Revisit: Harmonic Power Flow Measurements with PQMS

Hardware Coupling:

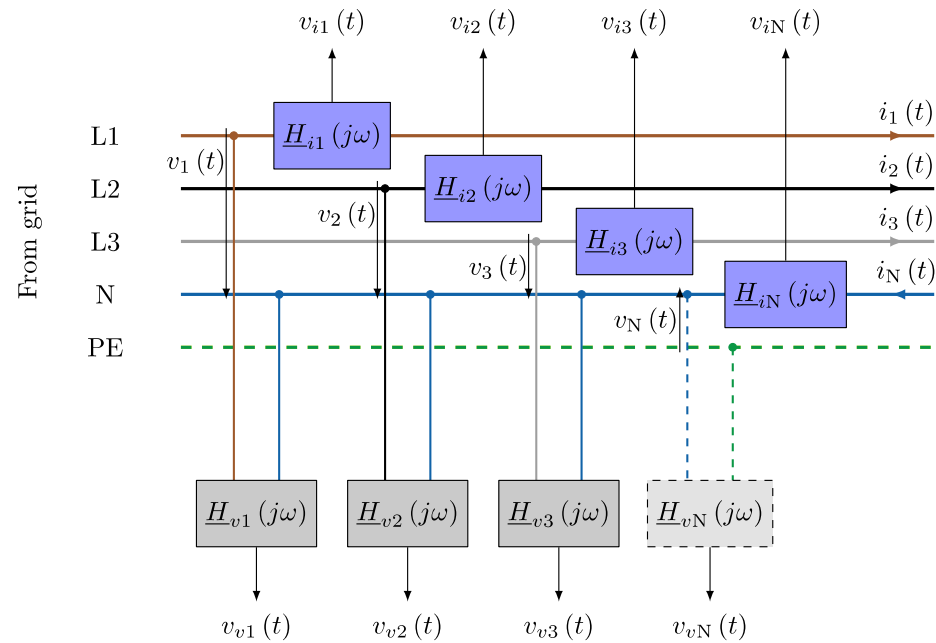

Measurement Concept:

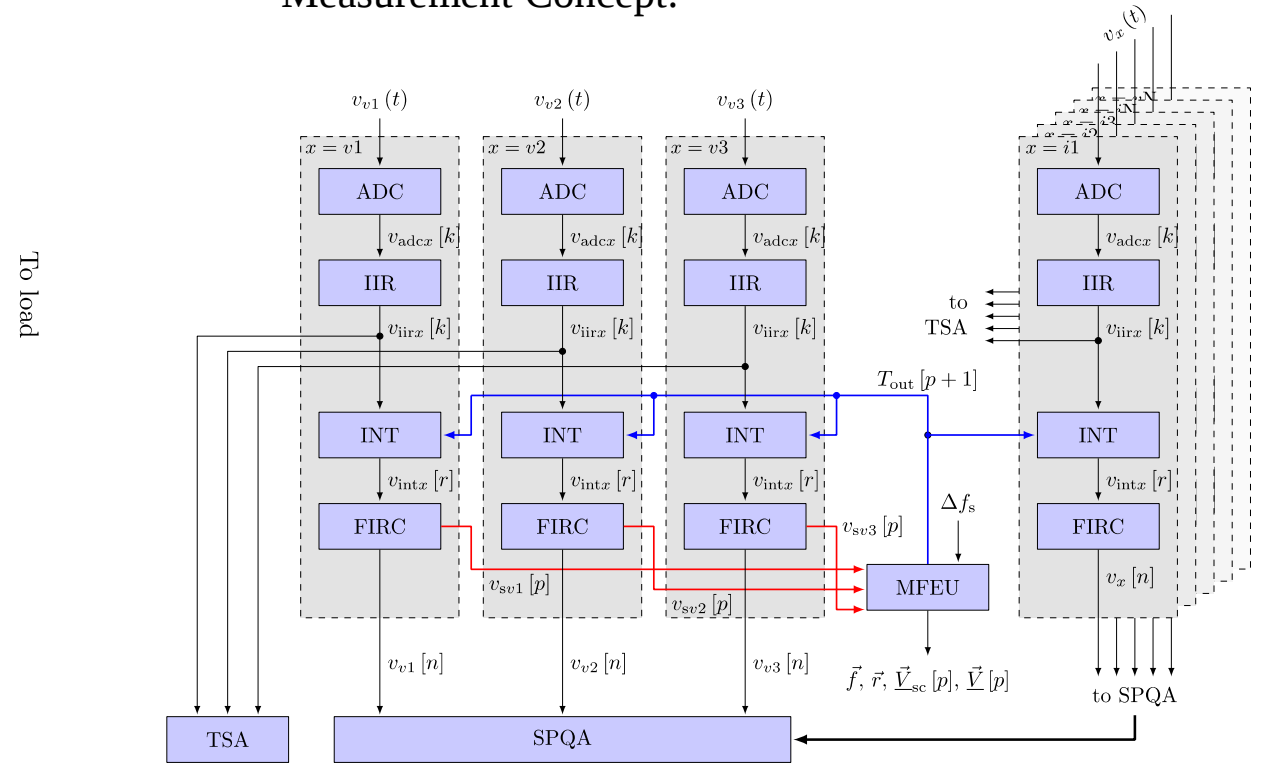

## Revisit: Advantages of Synchronous Measurements

- Period-wise spectral analysis with magnitude and phase of voltage and current signals

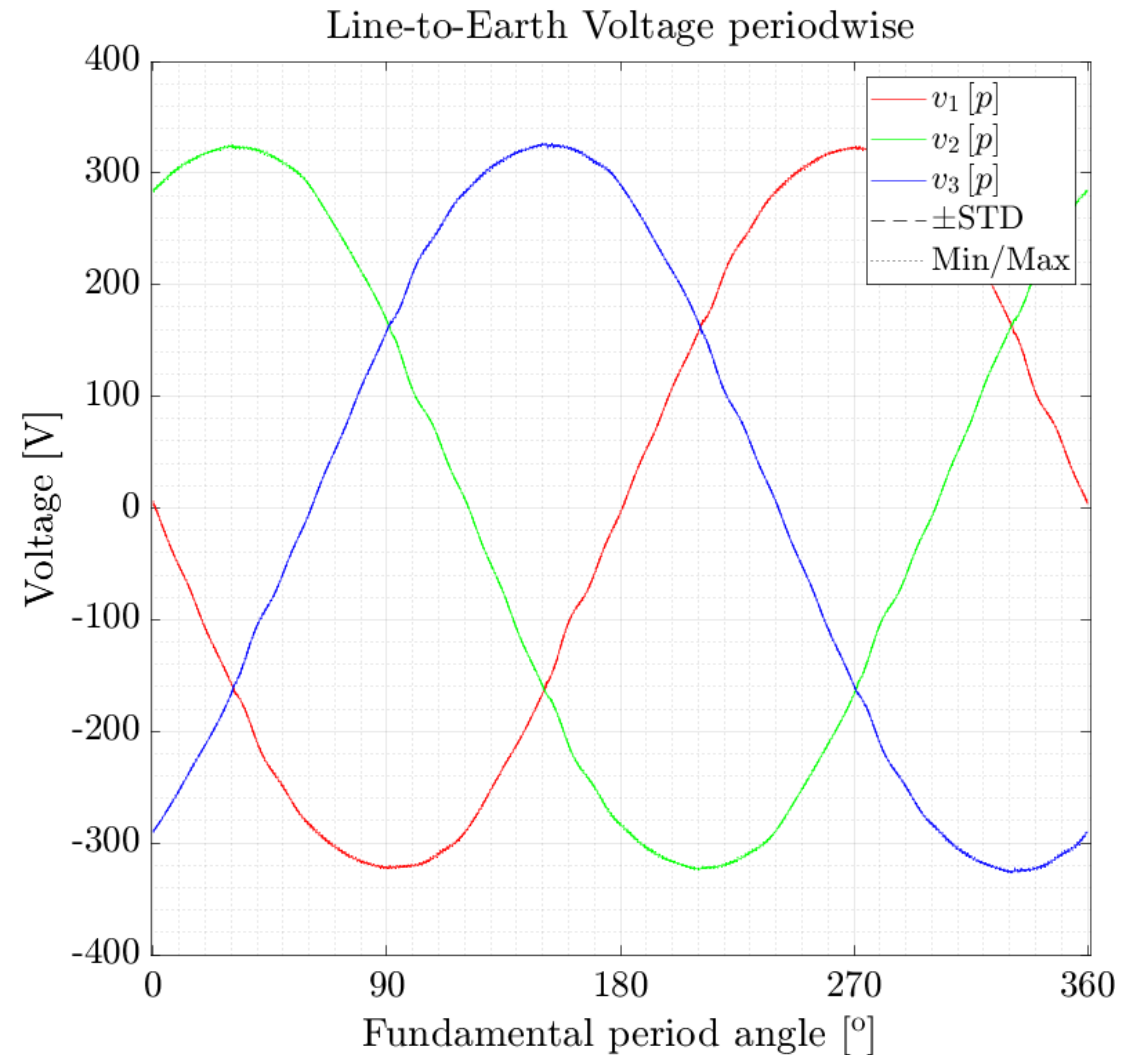

## Revisit: Advantages of Synchronous Measurements

- Period-wise spectral analysis with magnitude and phase of voltage and current signals

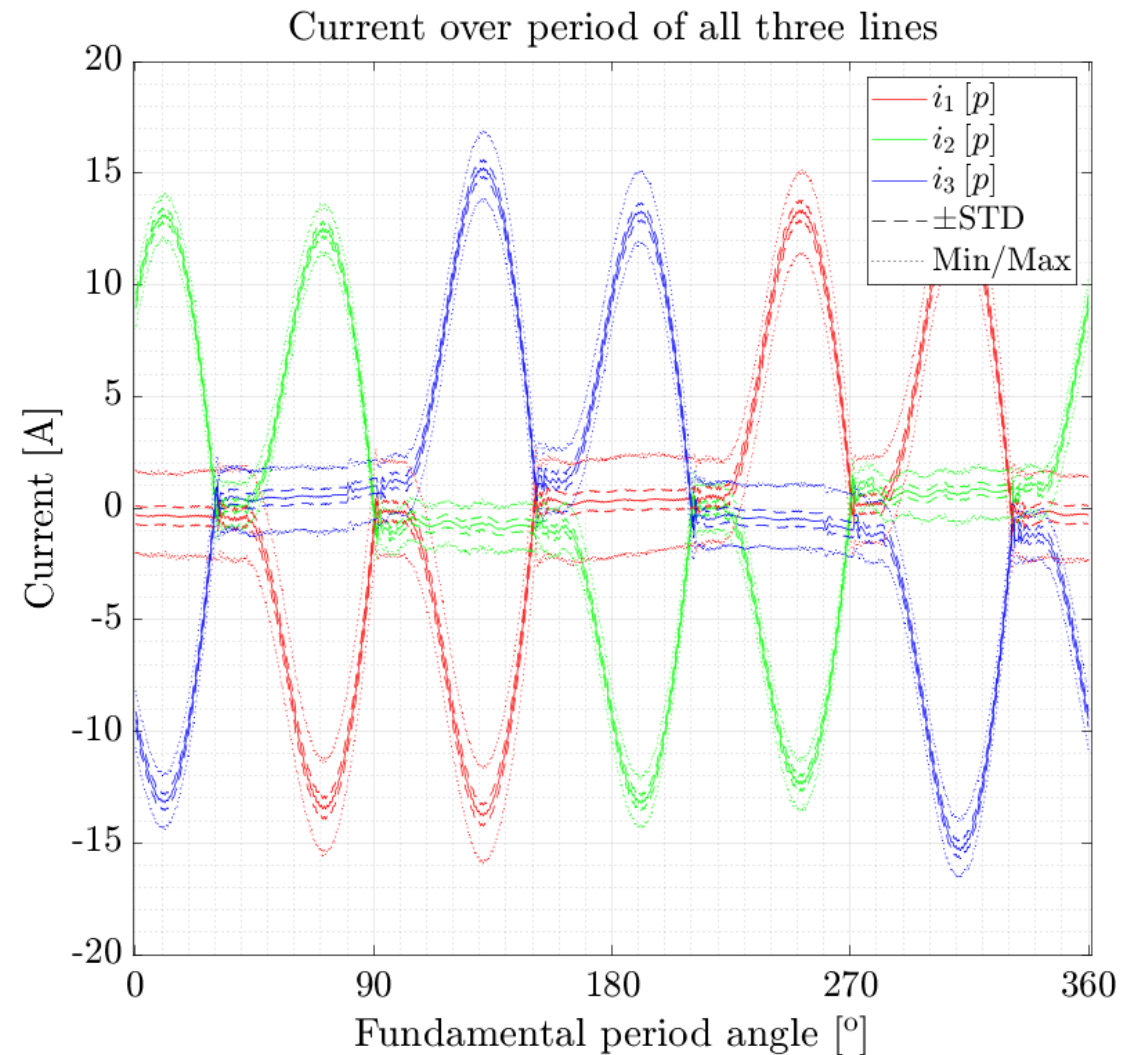

## Revisit: Advantages of Synchronous Measurements

- Period-wise spectral analysis with magnitude and phase of voltage and current signals
- No leakage error with mains frequency deviations

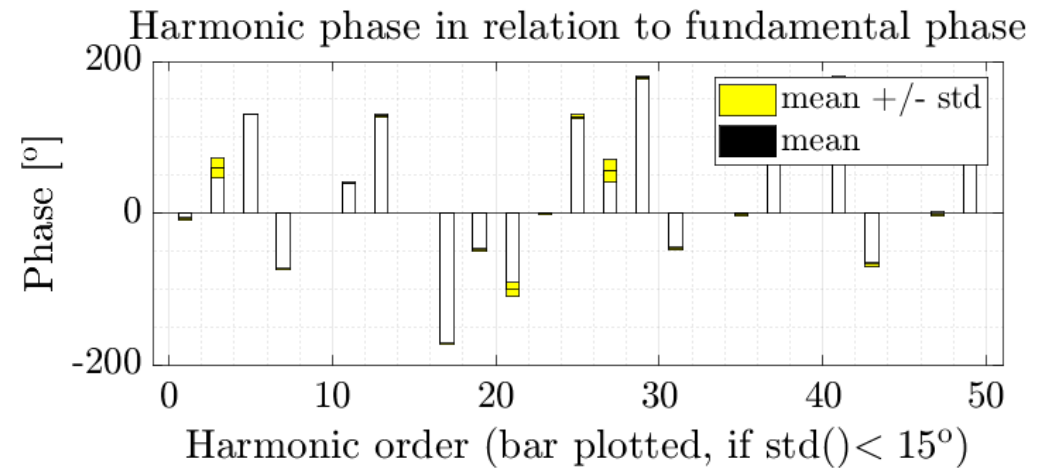
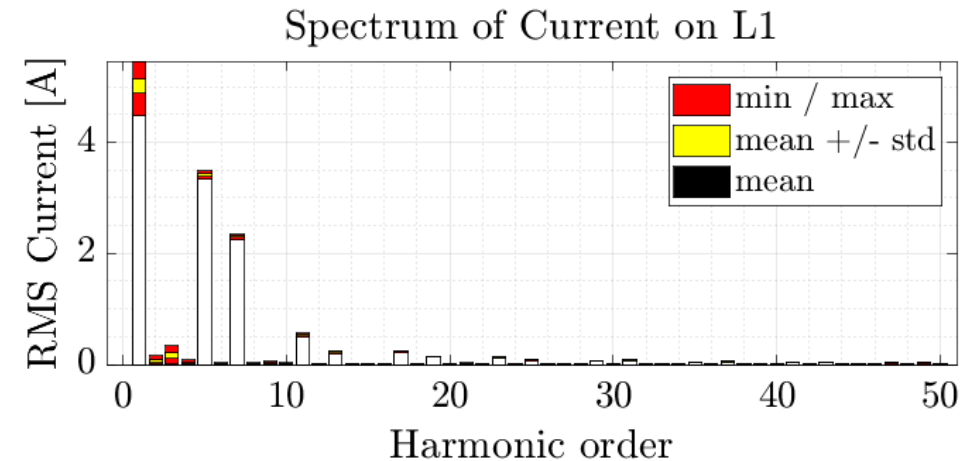

## Revisit: Advantages of Synchronous Measurements

- Period-wise spectral analysis with magnitude and phase of voltage and current signals
- No leakage error with mains frequency deviations
- High time resolution in spectral data (period-wise)

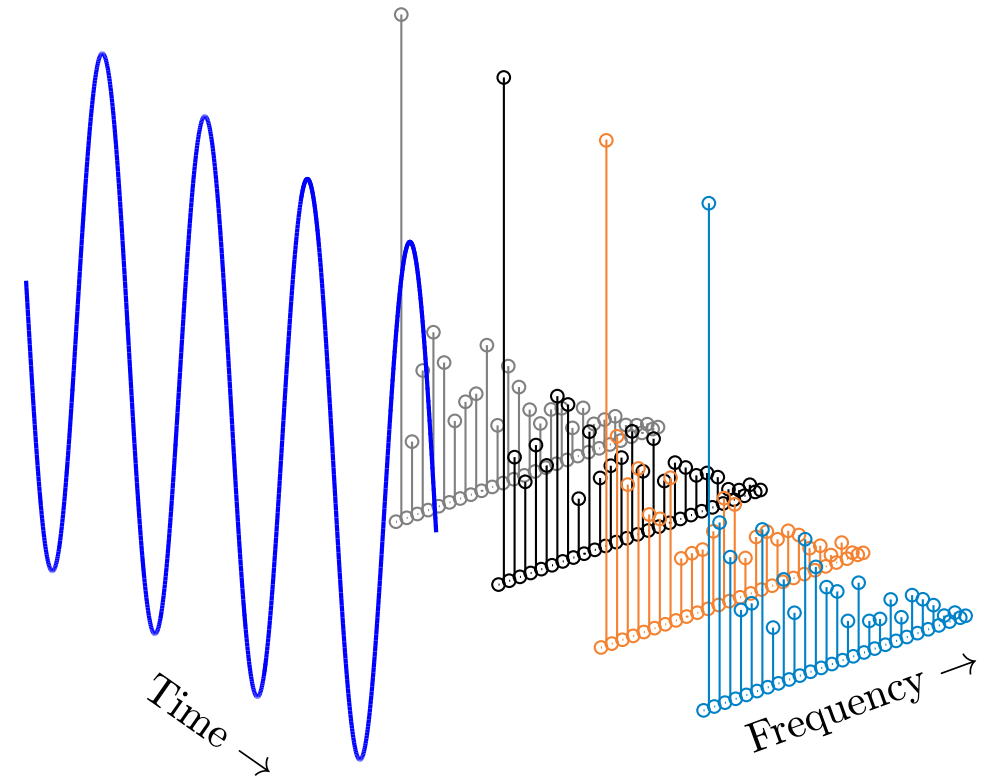

## Revisit: Advantages of Synchronous Measurements

- Period-wise spectral analysis with magnitude and phase of voltage and current signals
- No leakage error with mains frequency deviations
- High time resolution in spectral data (period-wise)
- Harmonic active power and impedance measurements

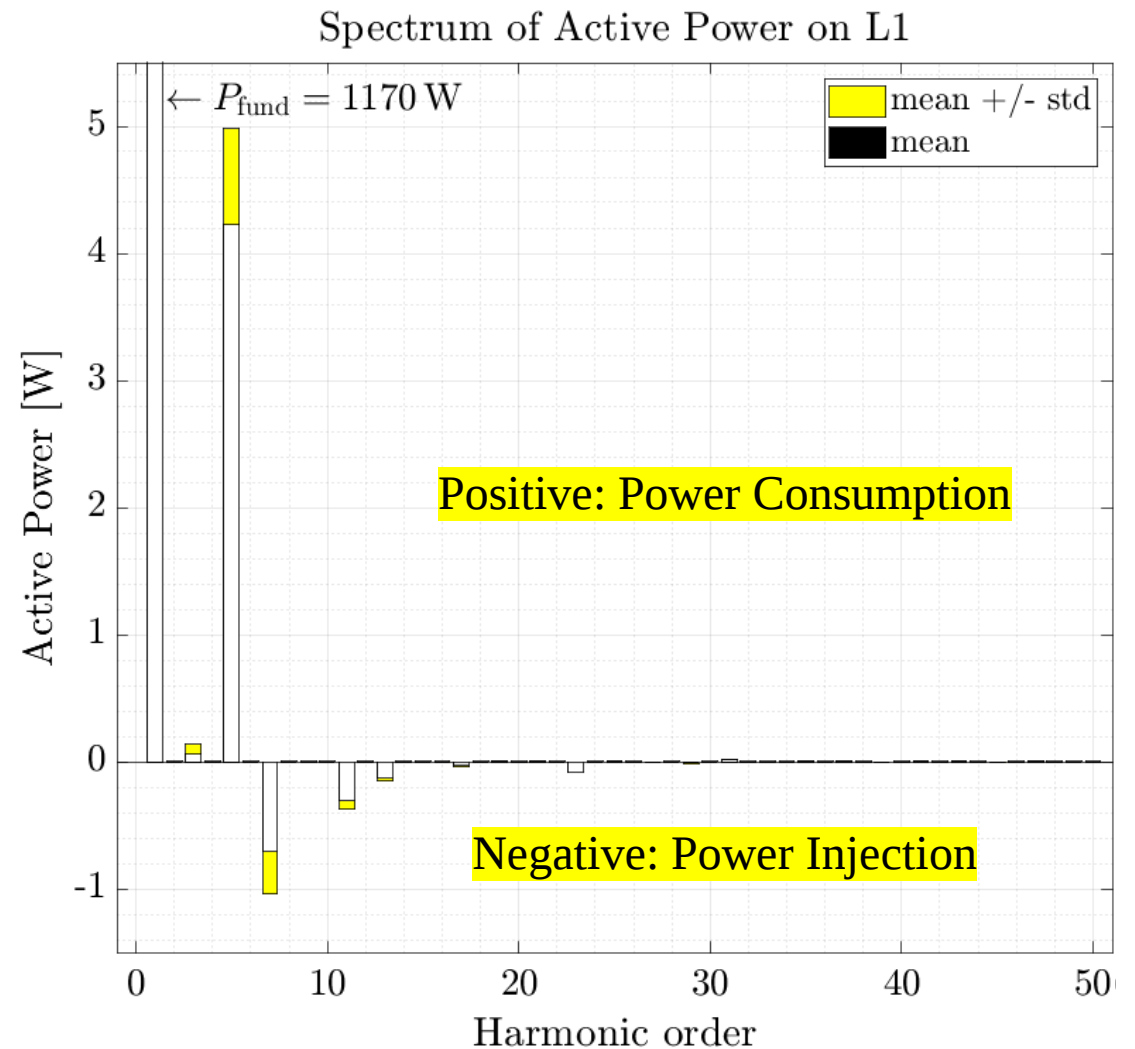



## The Case

- Medium-sized IT company in own office building

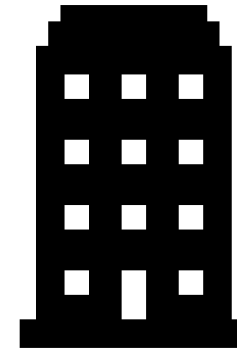

## The Case

- Medium-sized IT company in own office building
- Low voltage grid with no other participants

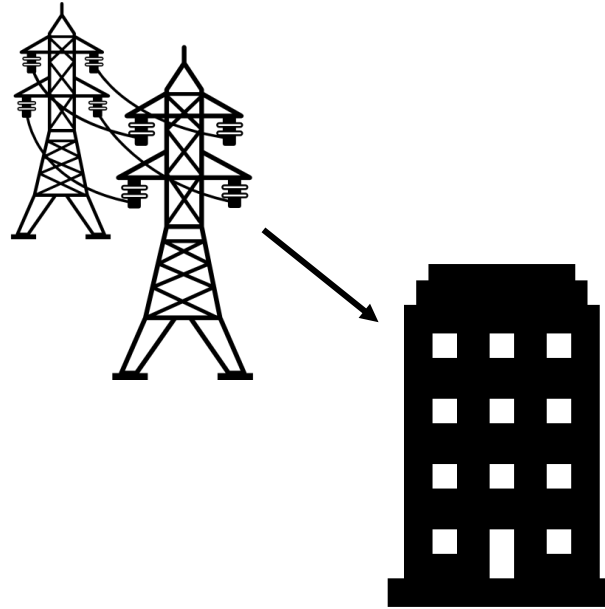

## The Case

- Medium-sized IT company in own office building
- Low voltage grid with no other participants
- 4 EV charging stations

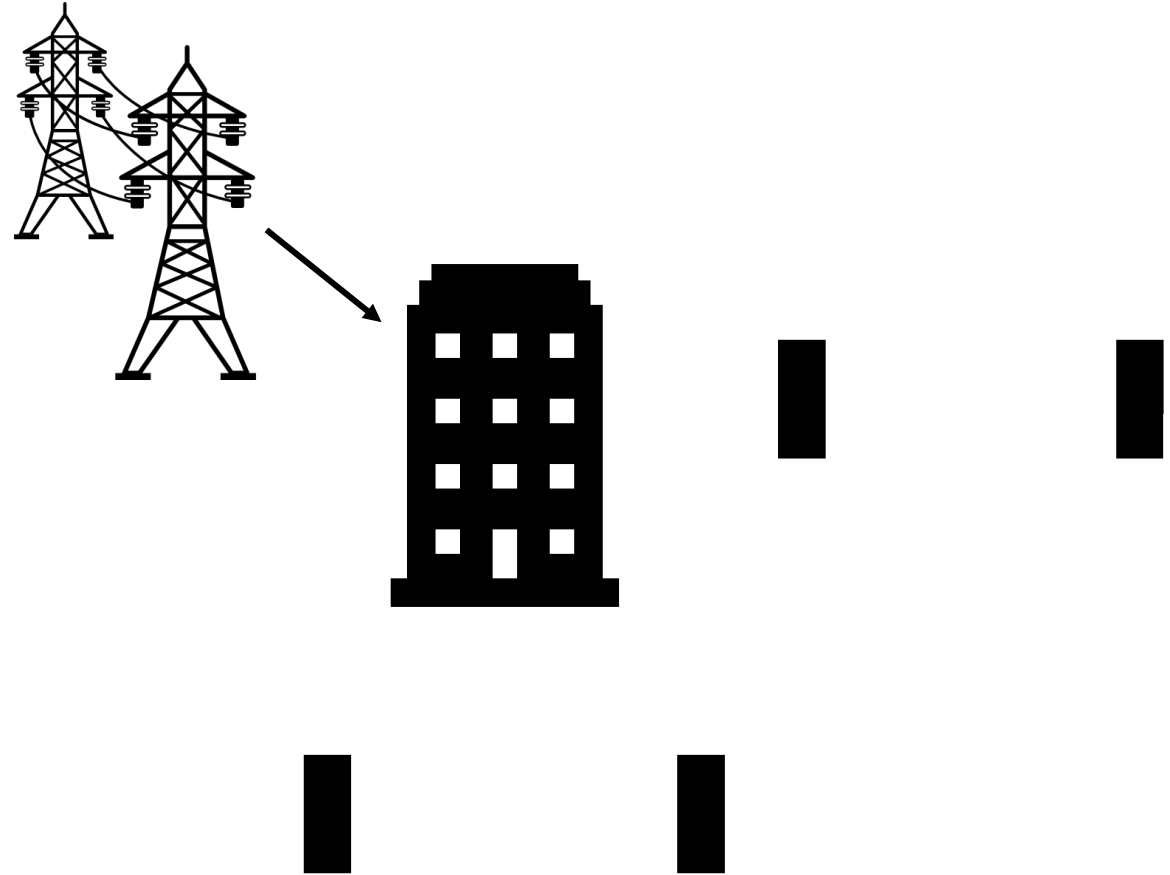

## The Case

- Medium-sized IT company in own office building
- Low voltage grid with no other participants
- 4 EV charging stations  
2 charging stations per string

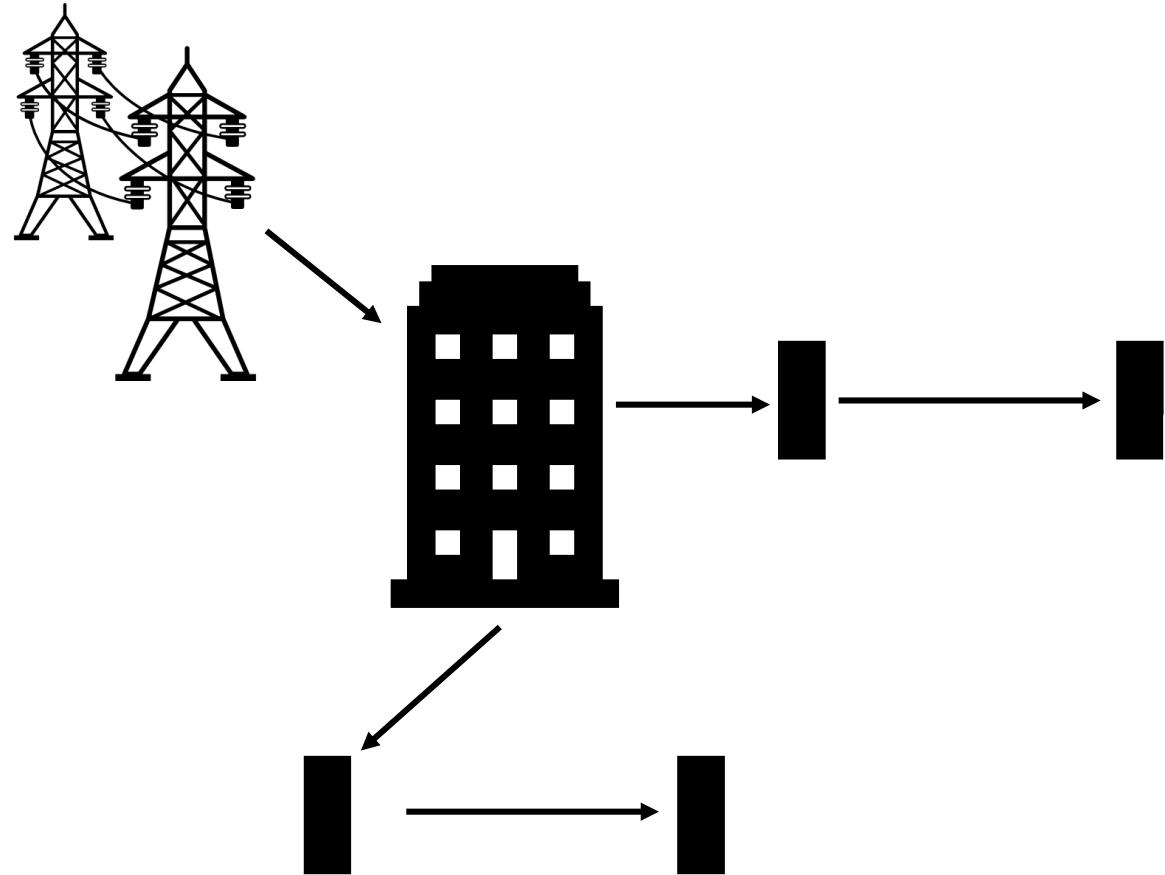

## The Case

- Medium-sized IT company in own office building
- Low voltage grid with no other participants
- 4 EV charging stations
  - 2 charging stations per string
  - 2 charging ports per station at 22kW AC
  - 44kW max. power per string

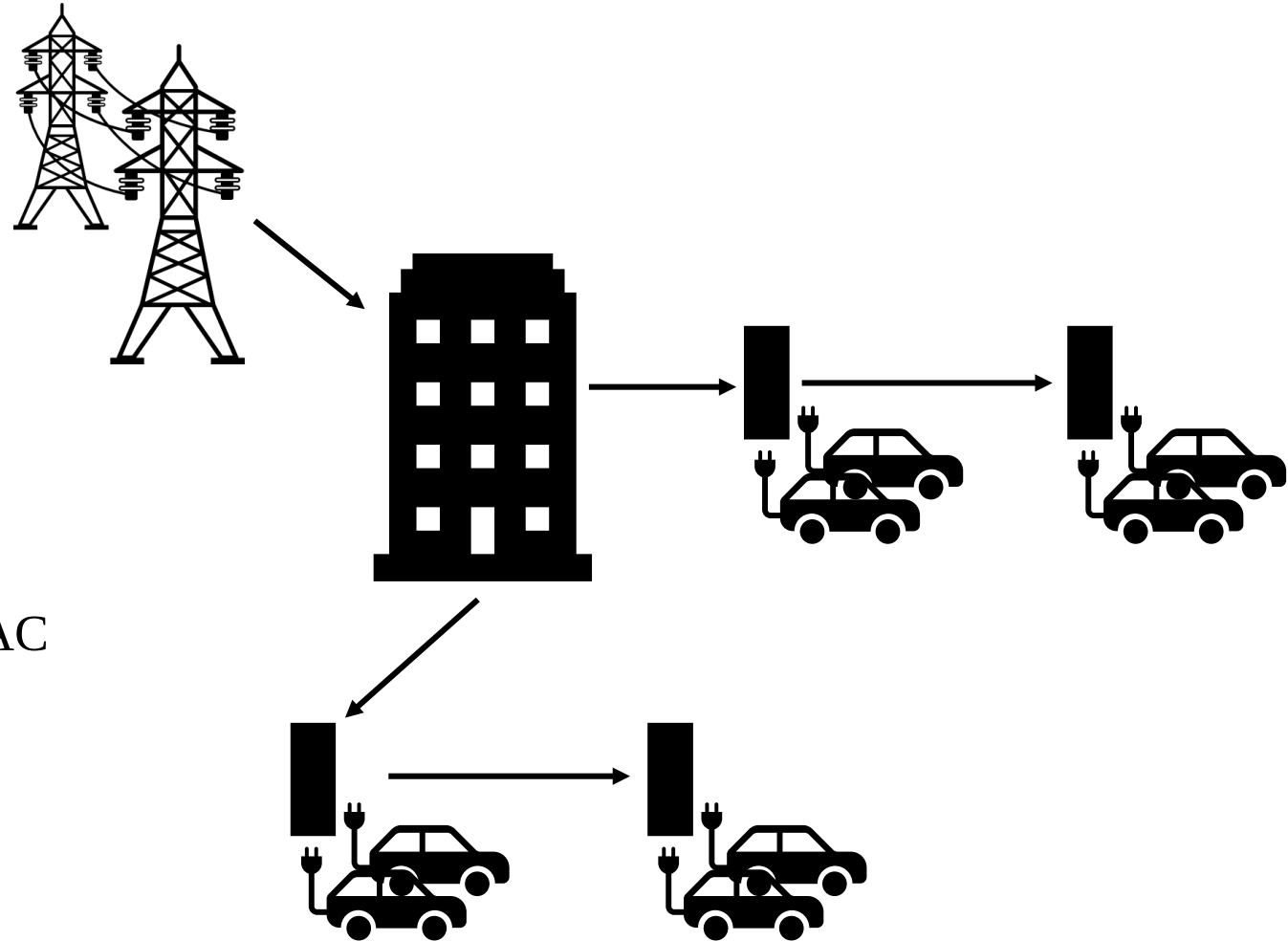

## The Case

- Medium-sized IT company in own office building
- Low voltage grid with no other participants
- 4 EV charging stations
  - 2 charging stations per string
  - 2 charging ports per station at 22kW AC
  - 44kW max. power per string
- 15kWp of photovoltaic generation

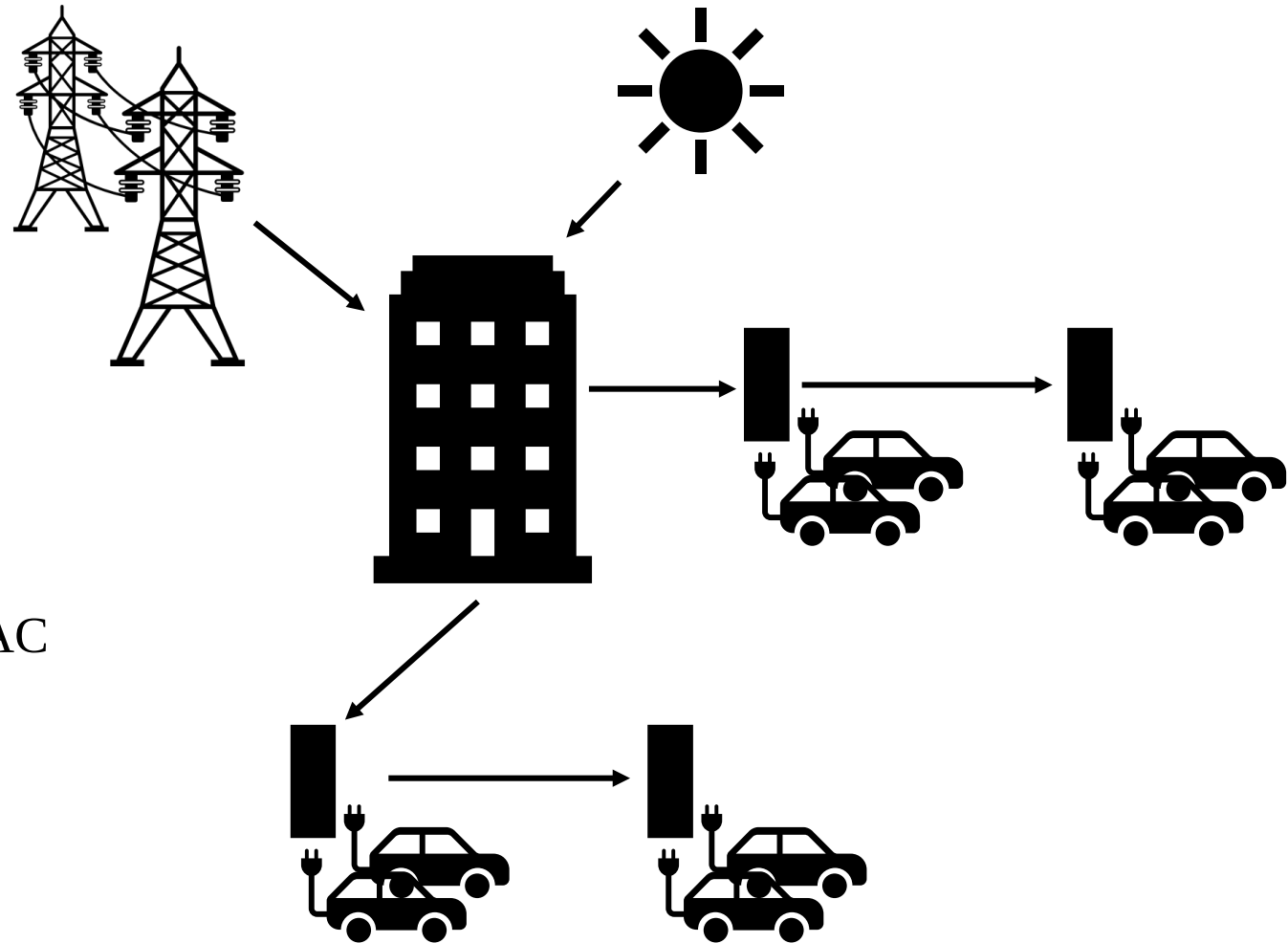

## The EV Charging Conditions

- 14x Small EV of french origin

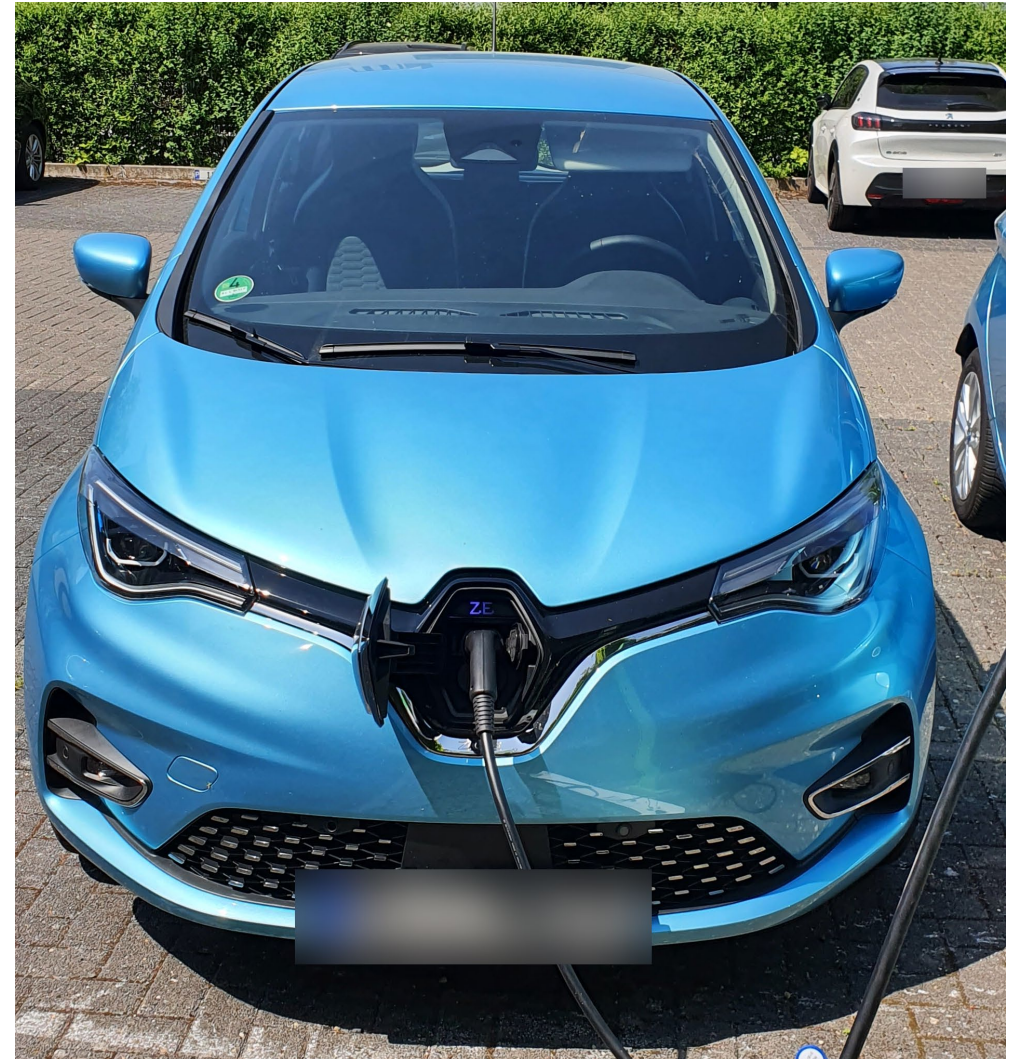



## The EV Charging Conditions

- 14x Small EV of french origin
- 2x 2 charging stations of 2 Outlets of 22kW each
- 2x Master/Slave configuration
- 88kW maximal total charging power





## The Problem

- Normal working conditions if no EV is charging

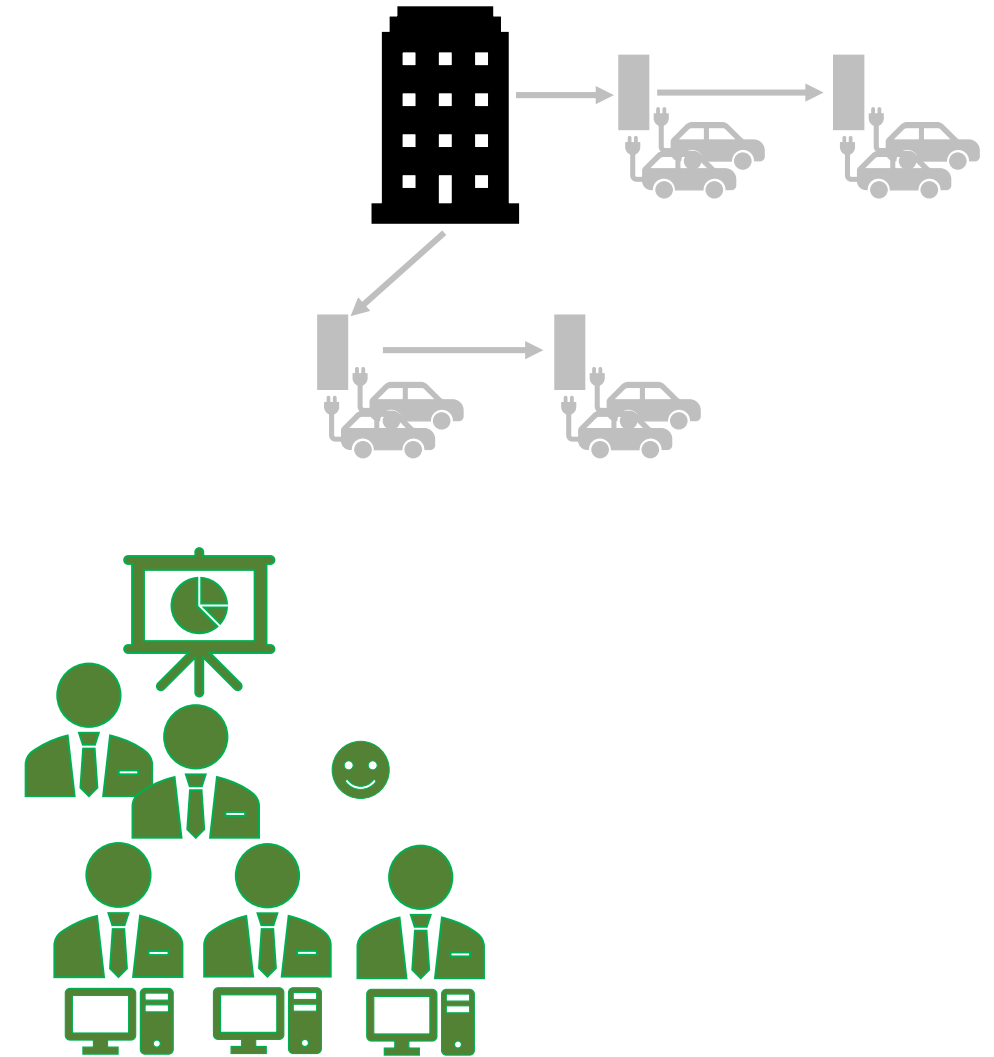

## The Problem

- Normal working conditions if no EV is charging
- 1 EV charging: High-pitched buzzing sound

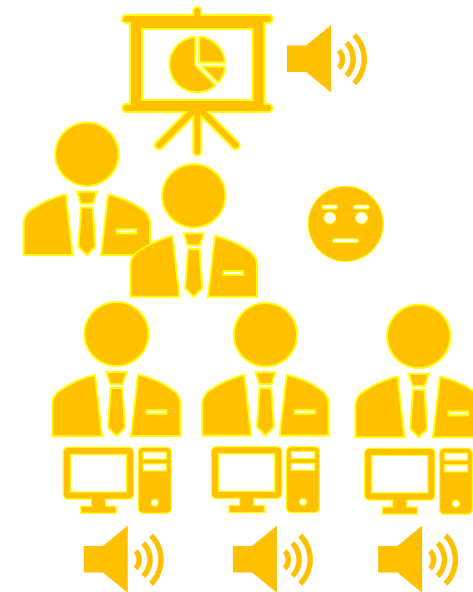
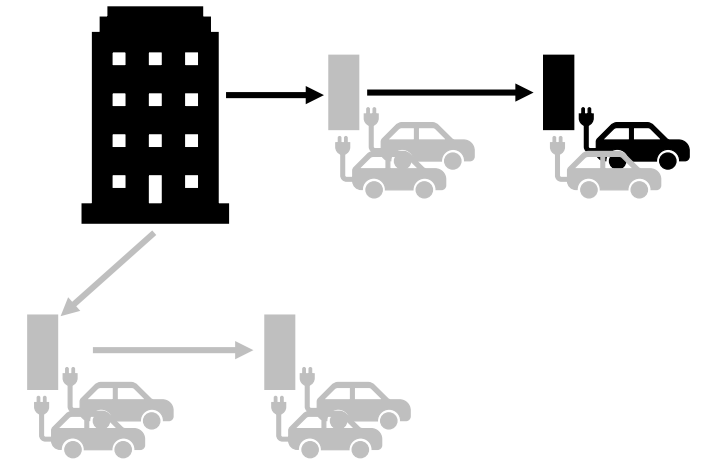

## The Problem

- Normal working conditions if no EV is charging
- 1 EV charging: High-pitched buzzing sound
- 2 or more EVs charging: Oscillating buzzing sound

Influence on the well-being of the employees in the workspace

EV manufacturer denies any responsibility

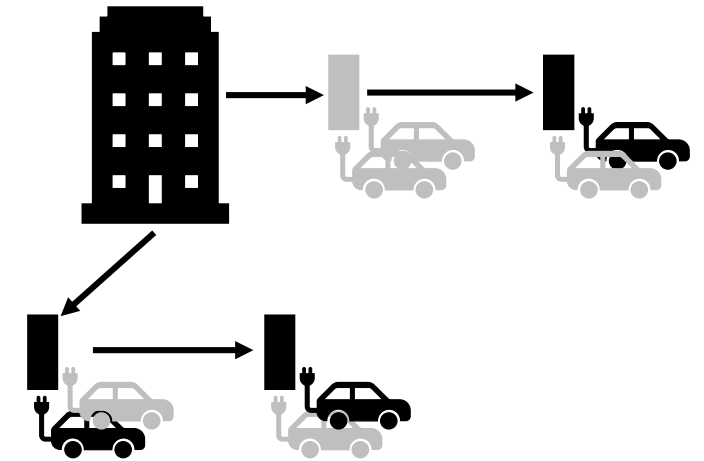

# Measurement Setup: LV Main Distribution Room





# Measurement Setup: Charging Station



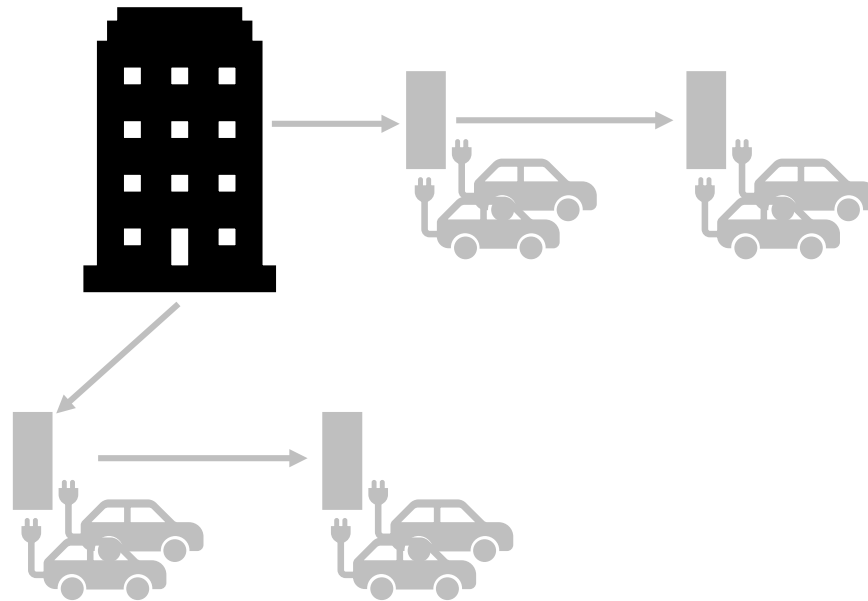

# Results: Power Grid in Idle

Measured in LV Distribution Room

# Results: Power Grid in Idle

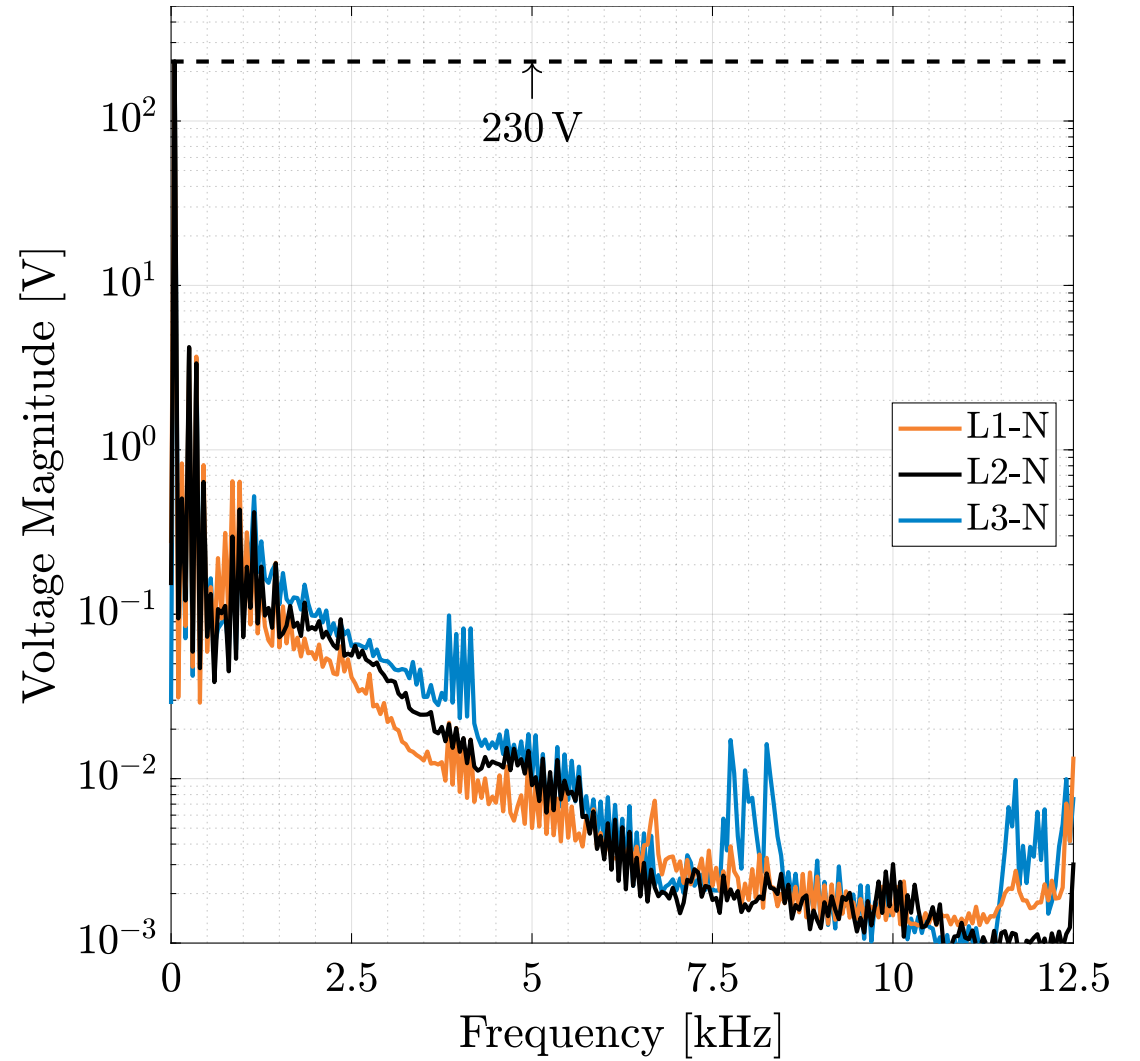
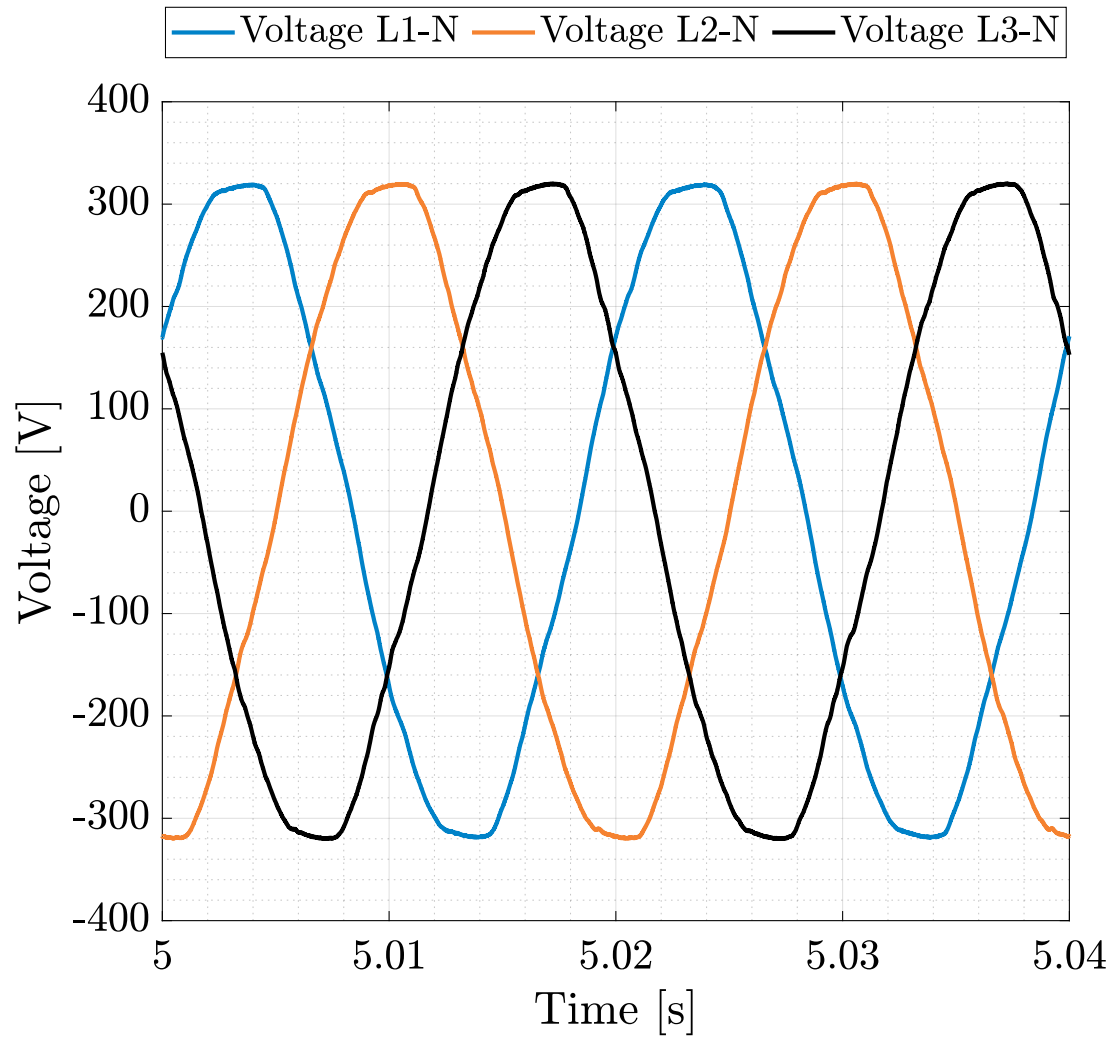

# Results: Power Grid in Idle

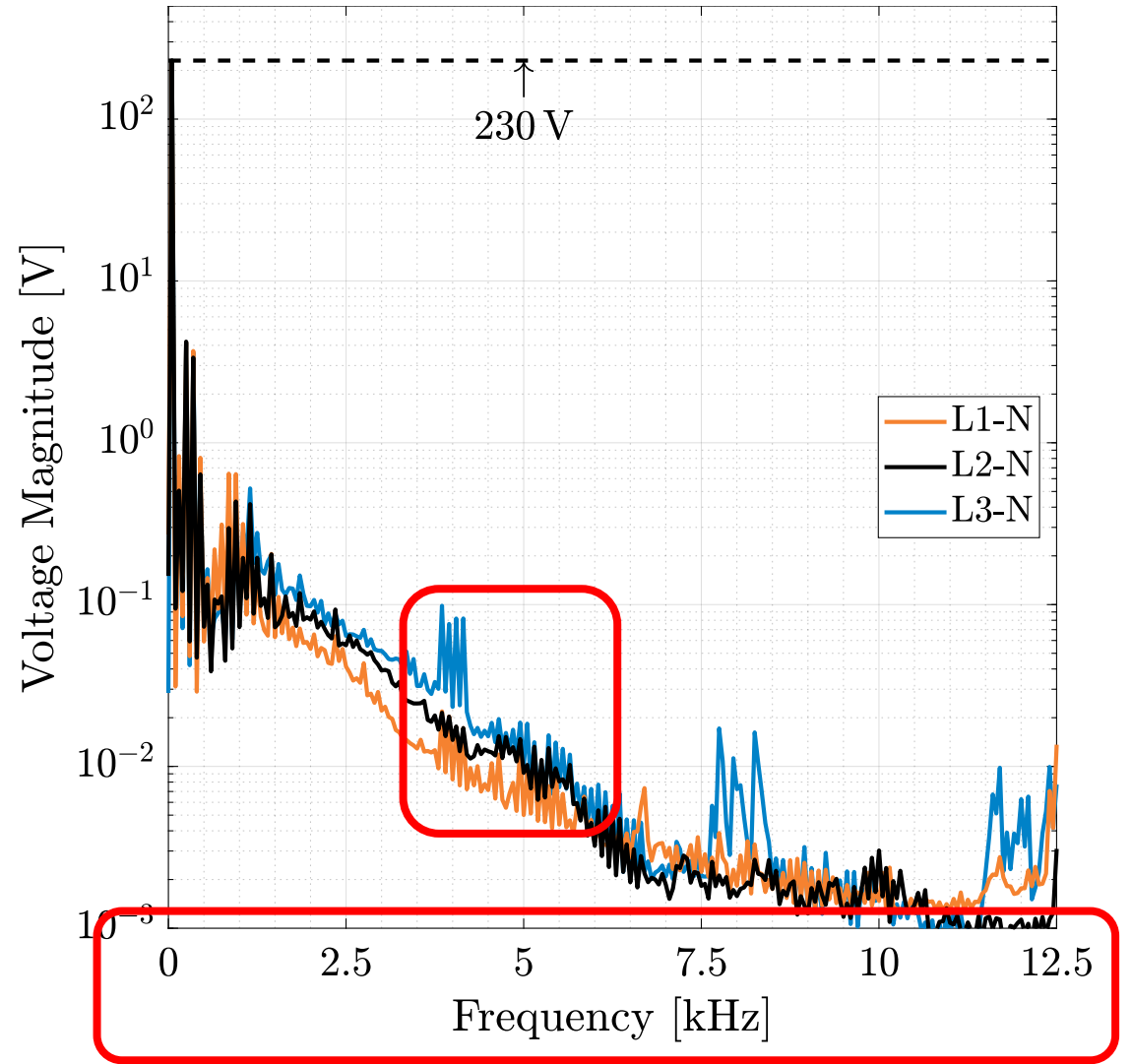
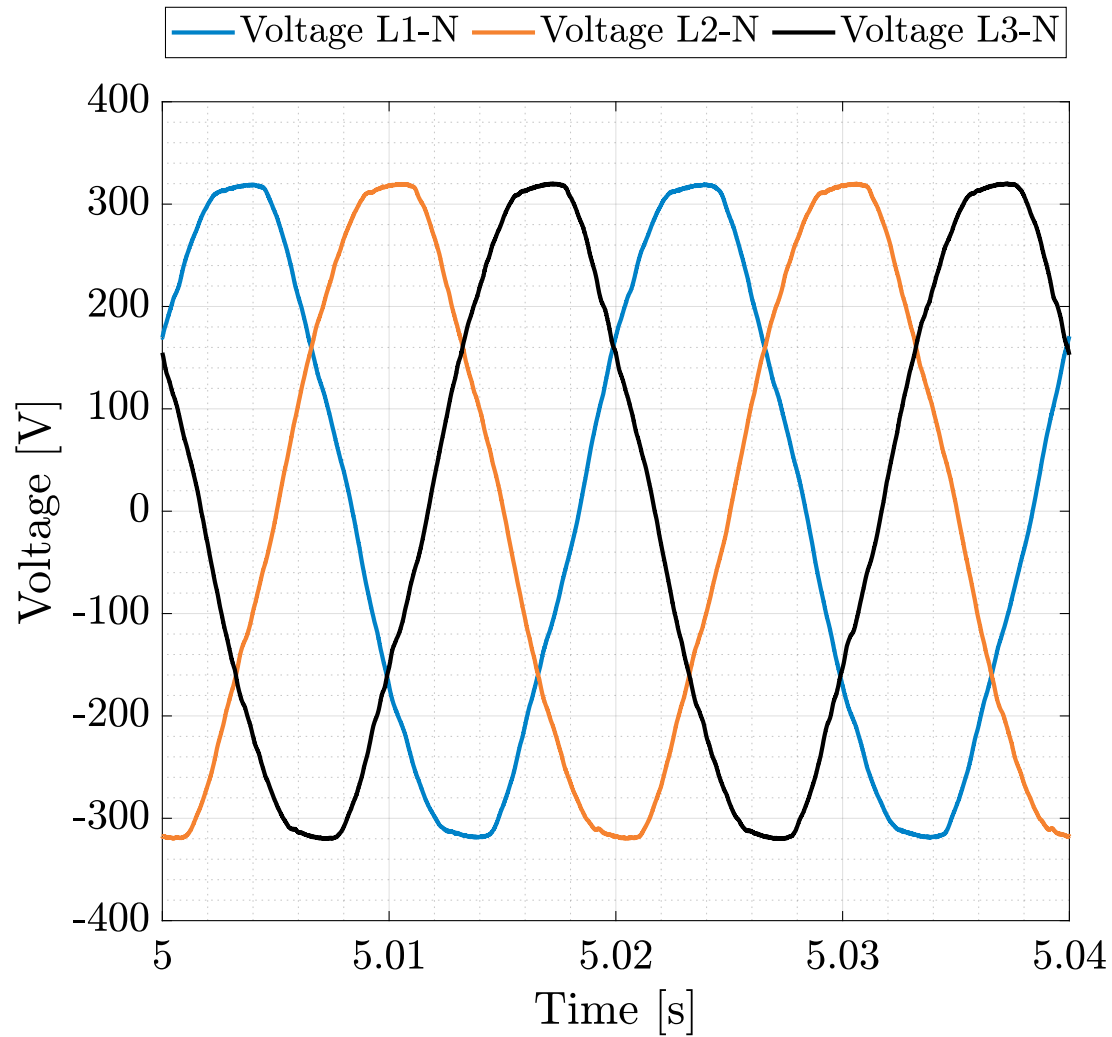



# Results: Power Grid in Idle

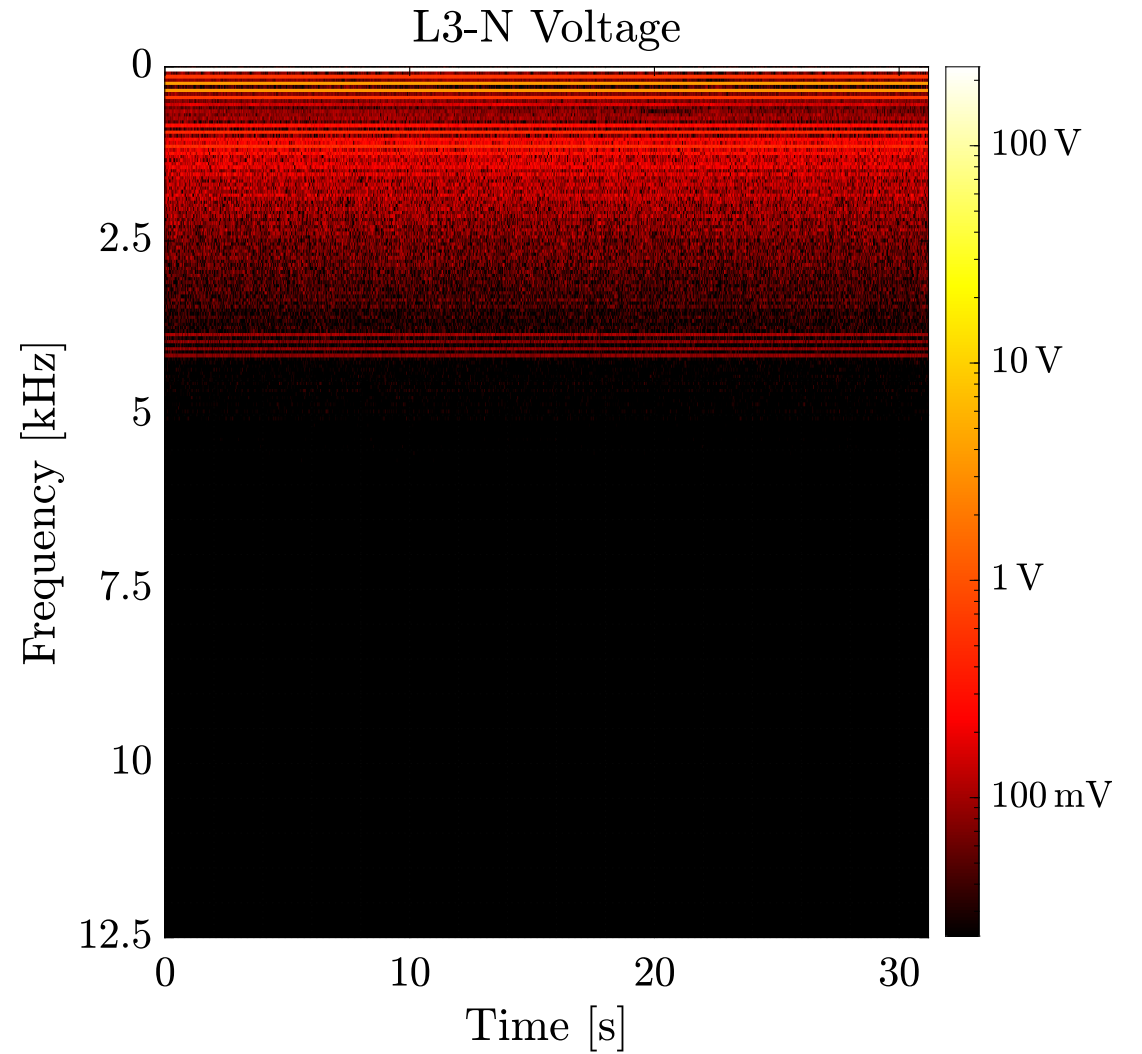
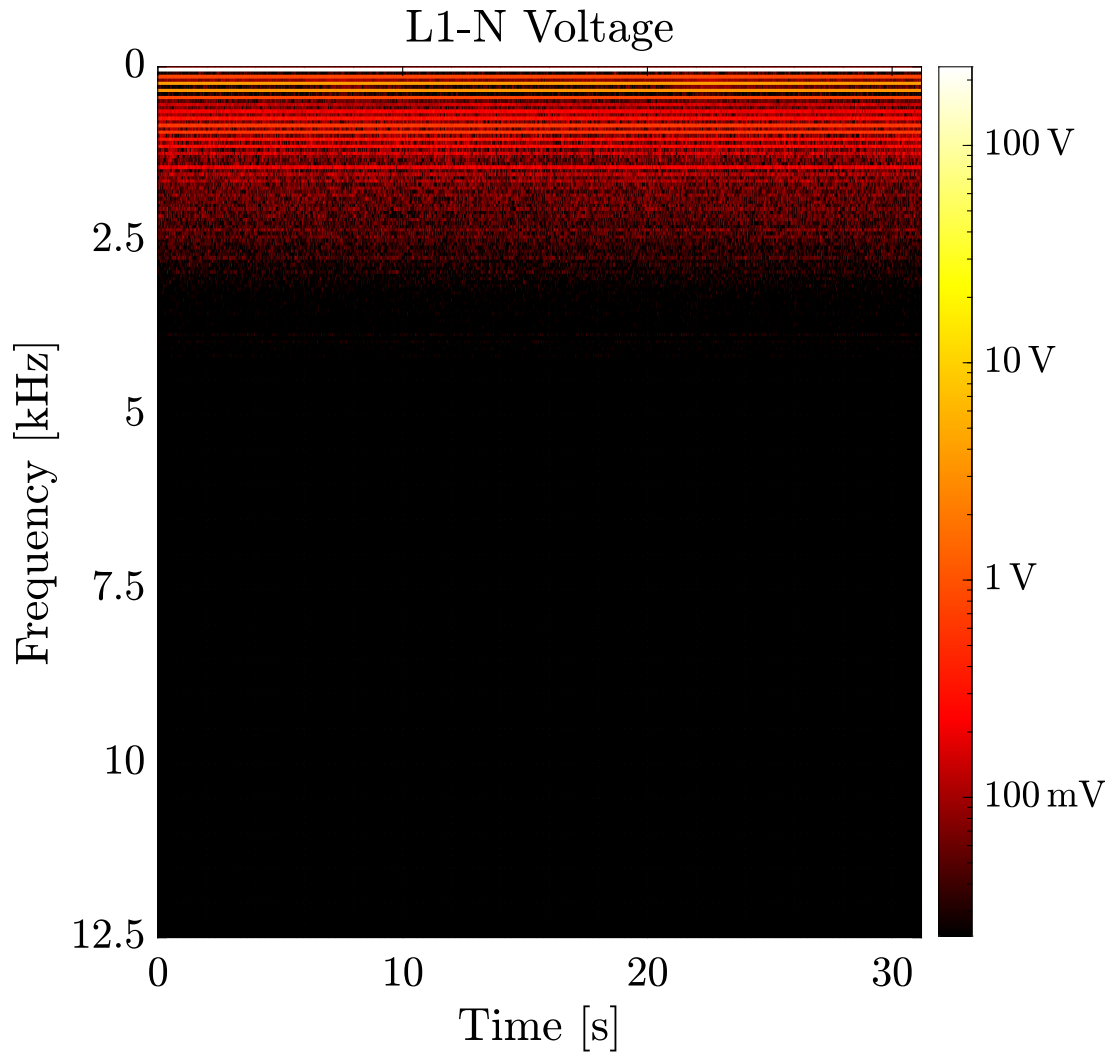

# Results: Power Grid in Idle

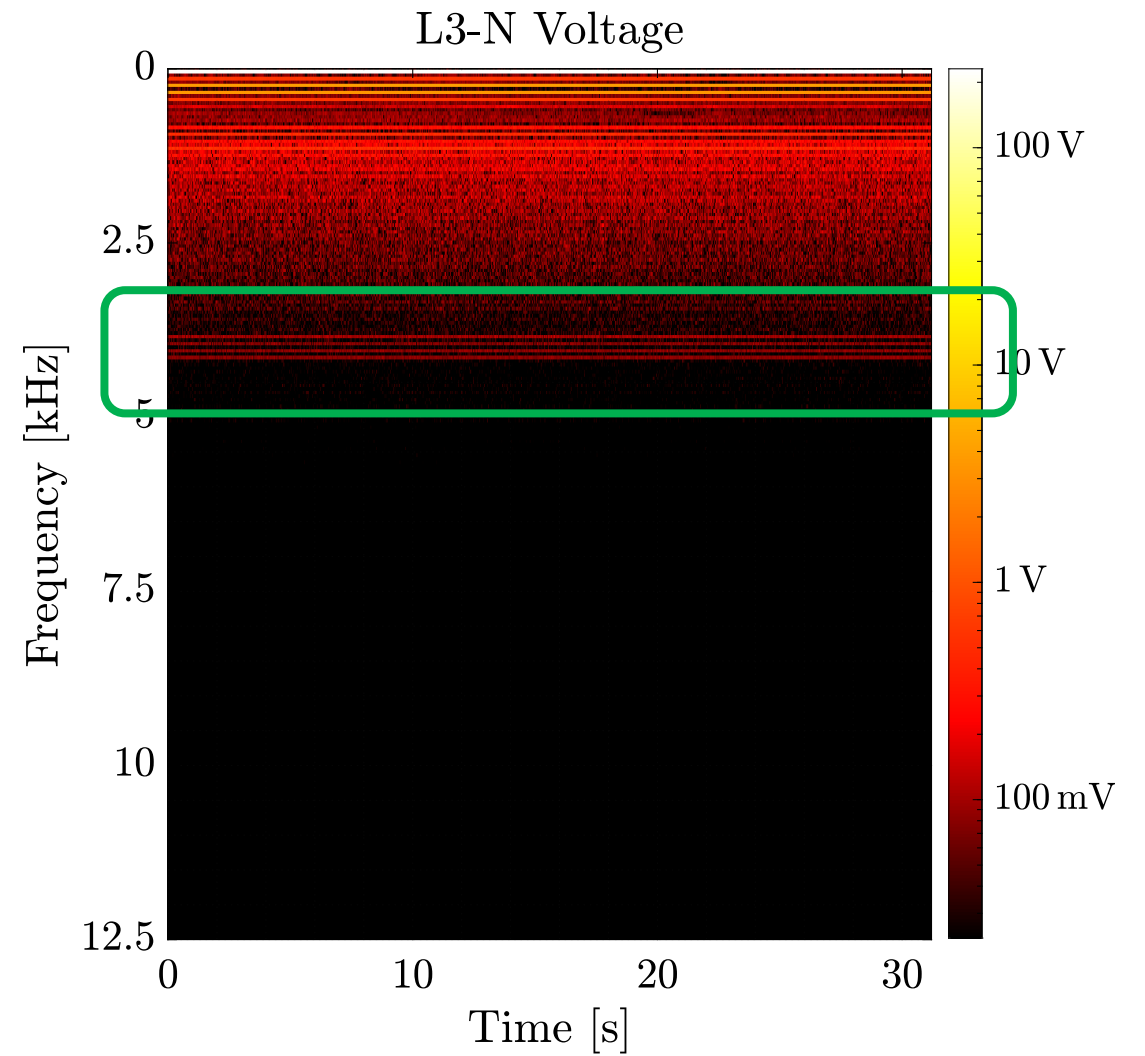
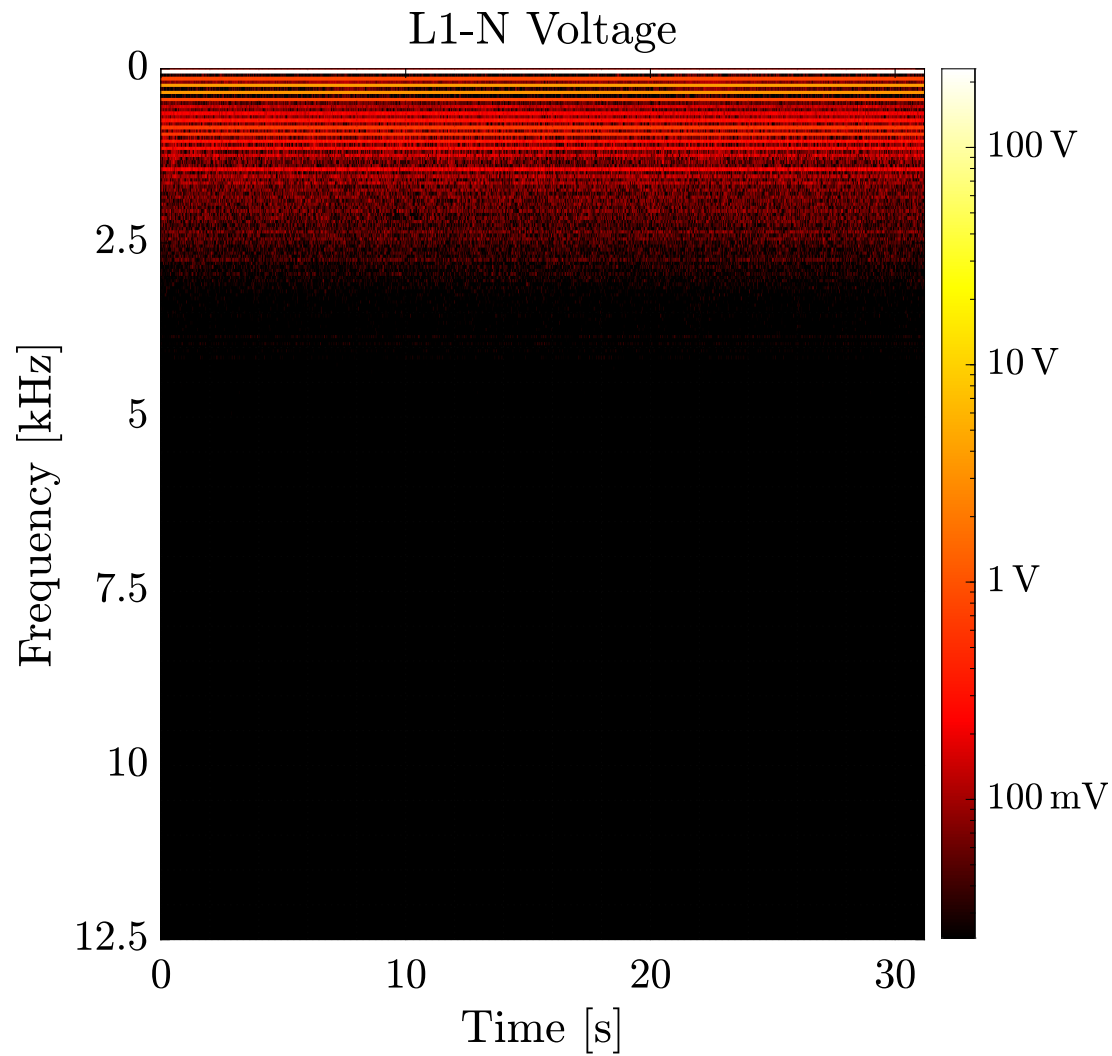

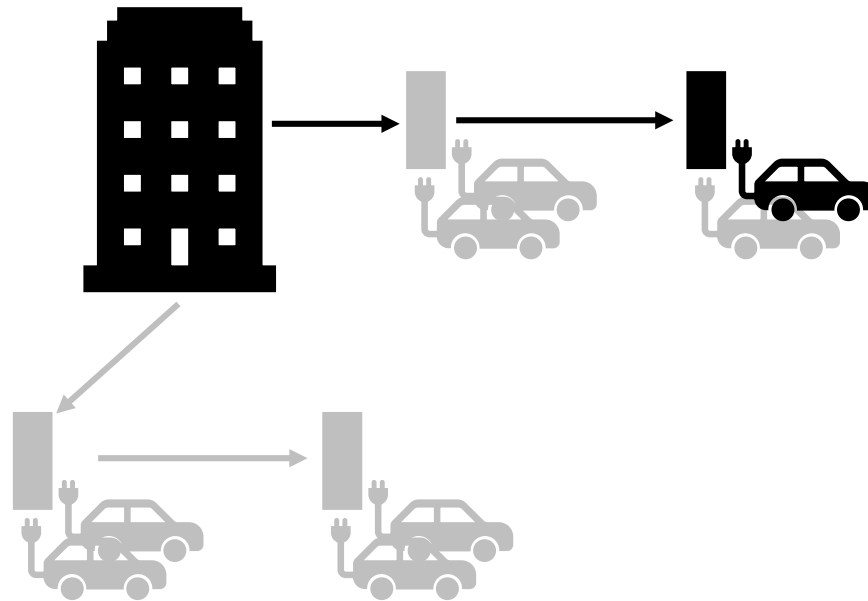

# Results: 1 EV Charging

Measured in LV Distribution Room

## Results: 1 EV Charging, Measured in LV Distribution Room

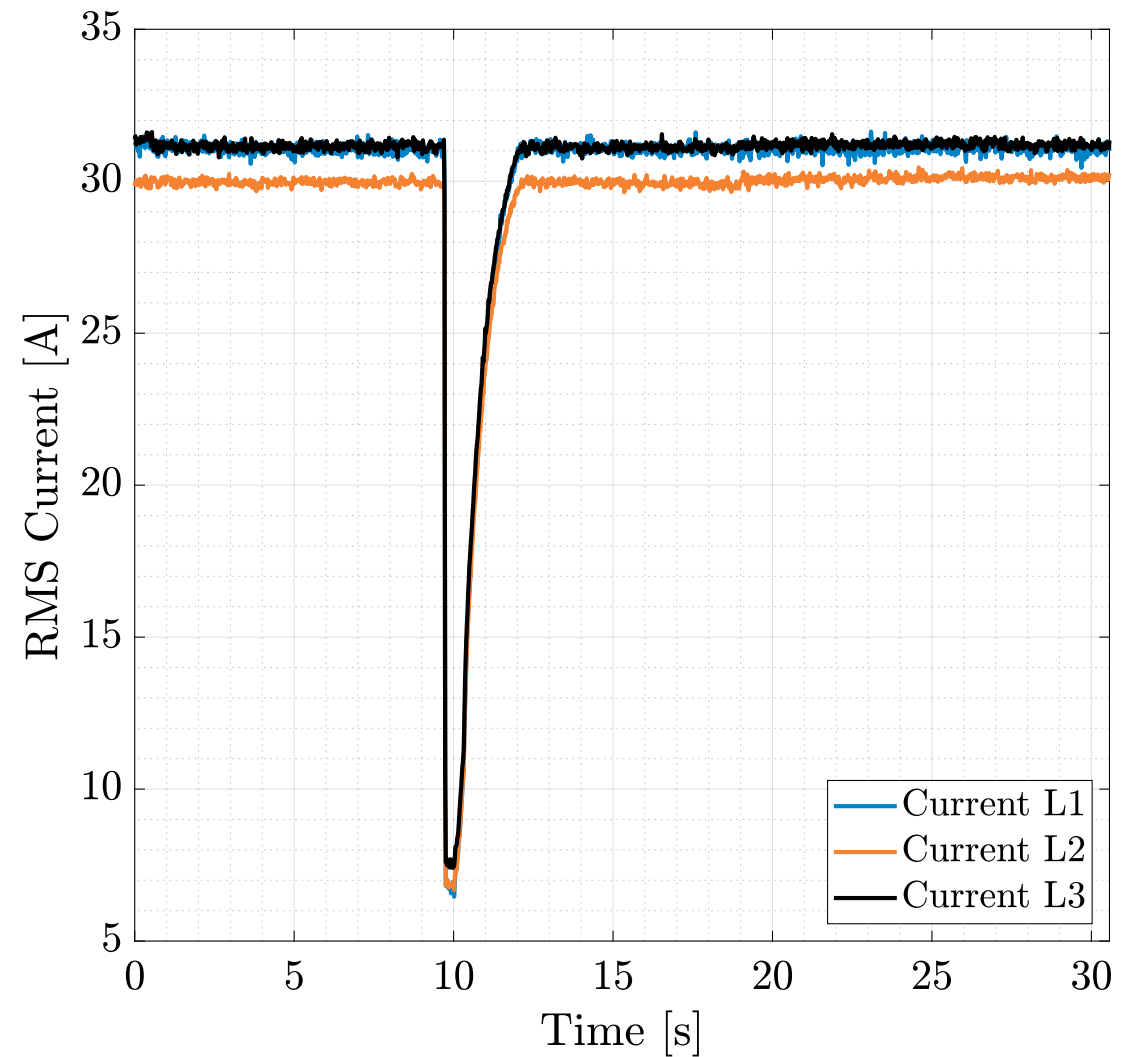
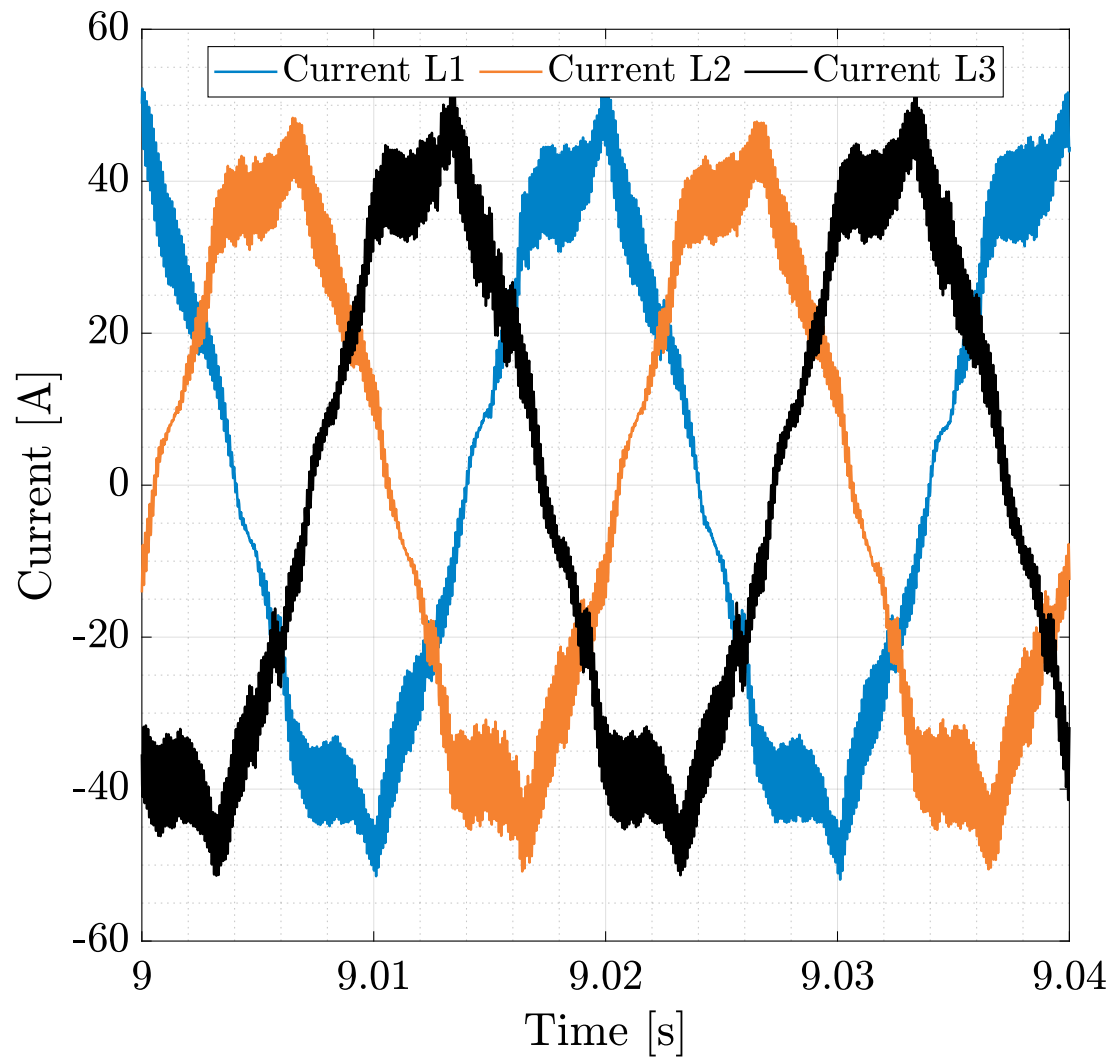

## Results: 1 EV Charging, Measured in LV Distribution Room

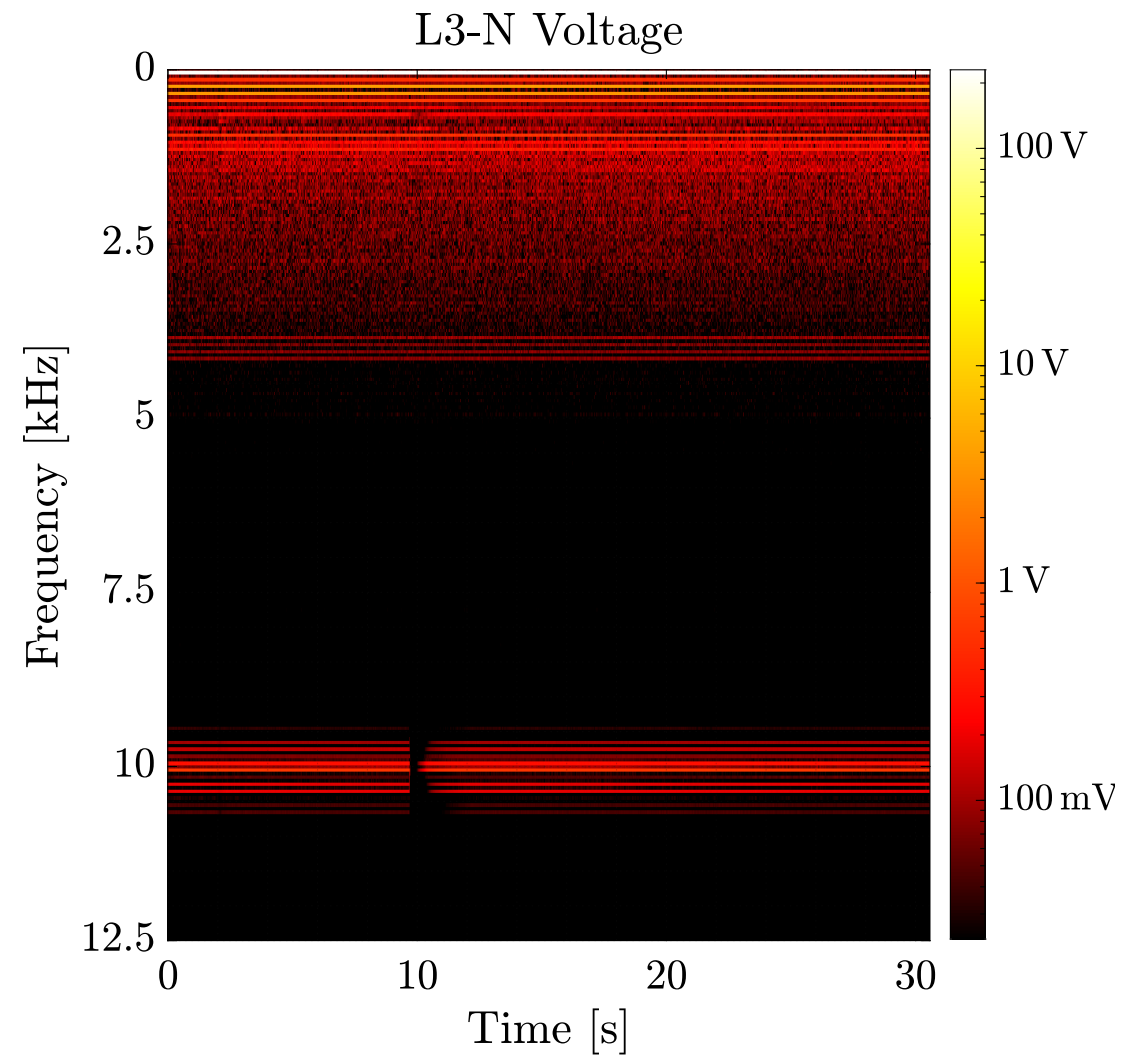
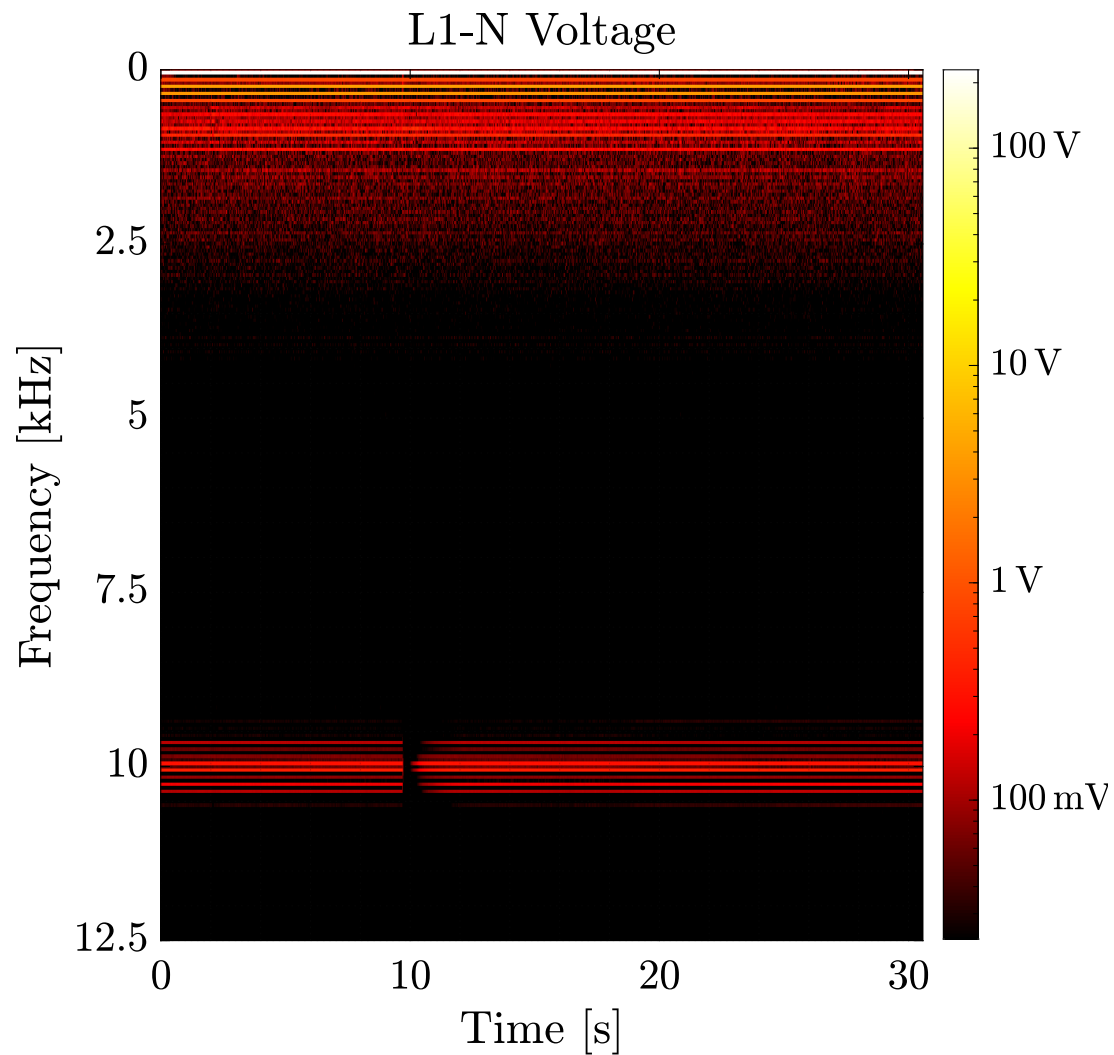

## Results: 1 EV Charging, Measured in LV Distribution Room

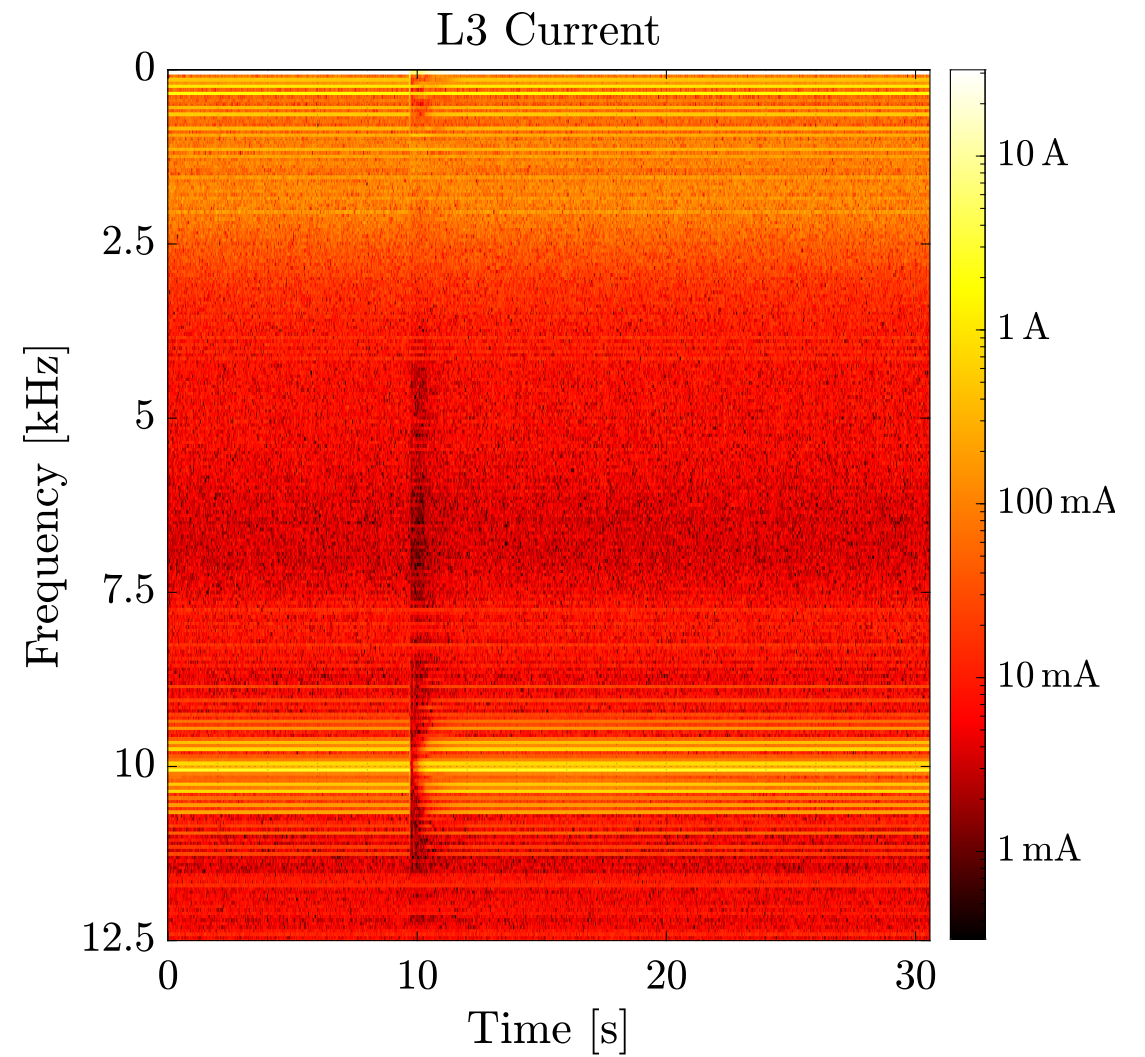
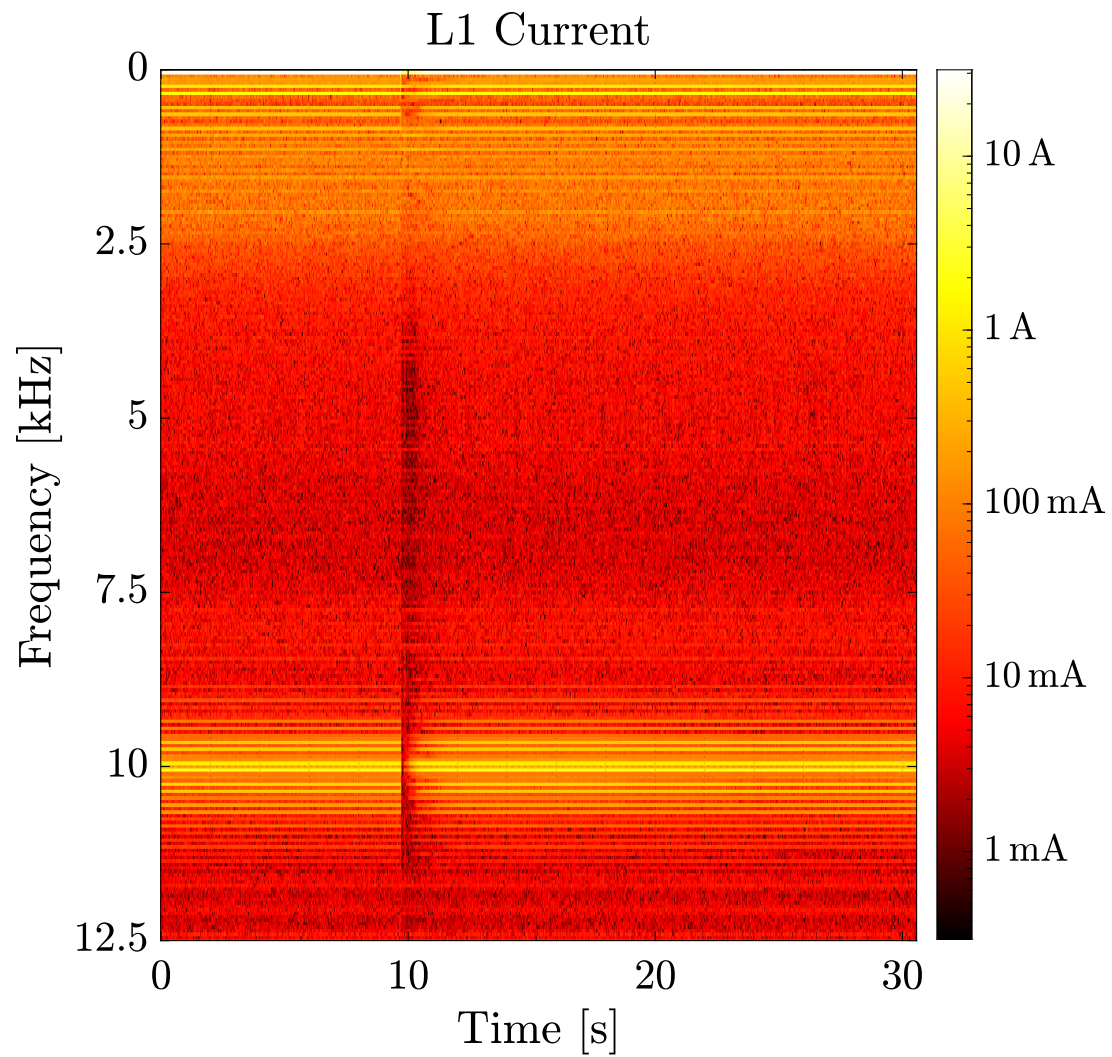

## Results: 1 EV Charging, Measured in LV Distribution Room

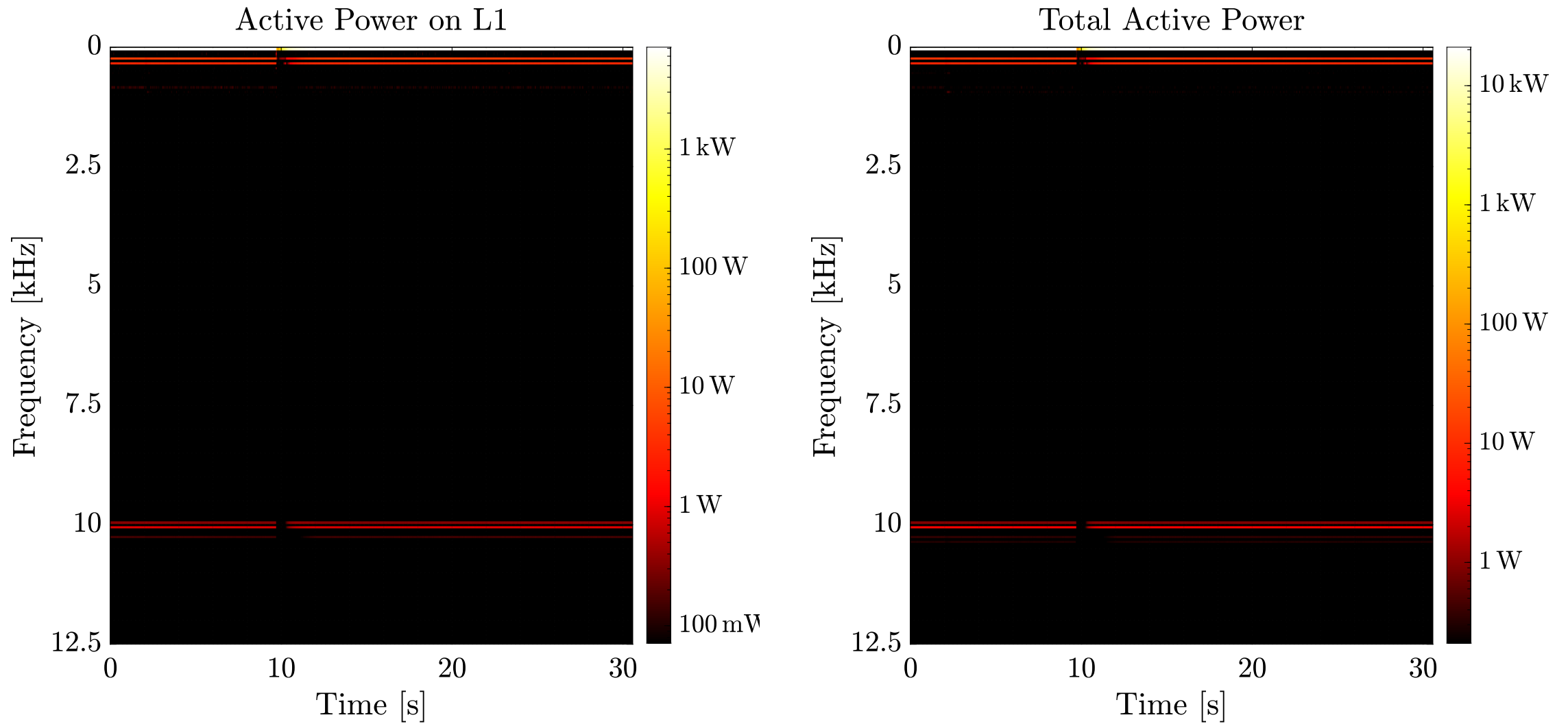

## Results: 1 EV Charging, Measured in LV Distribution Room

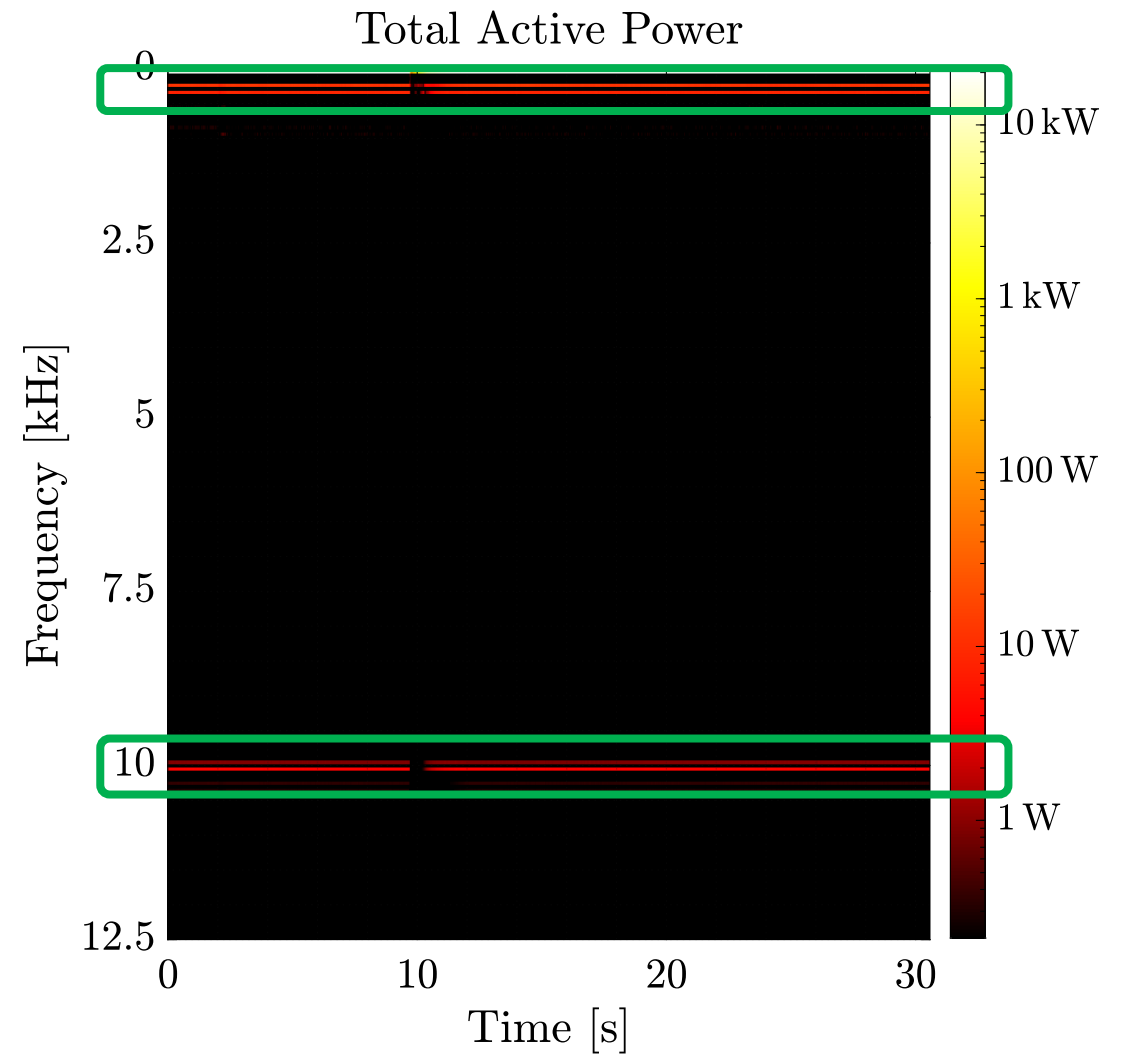
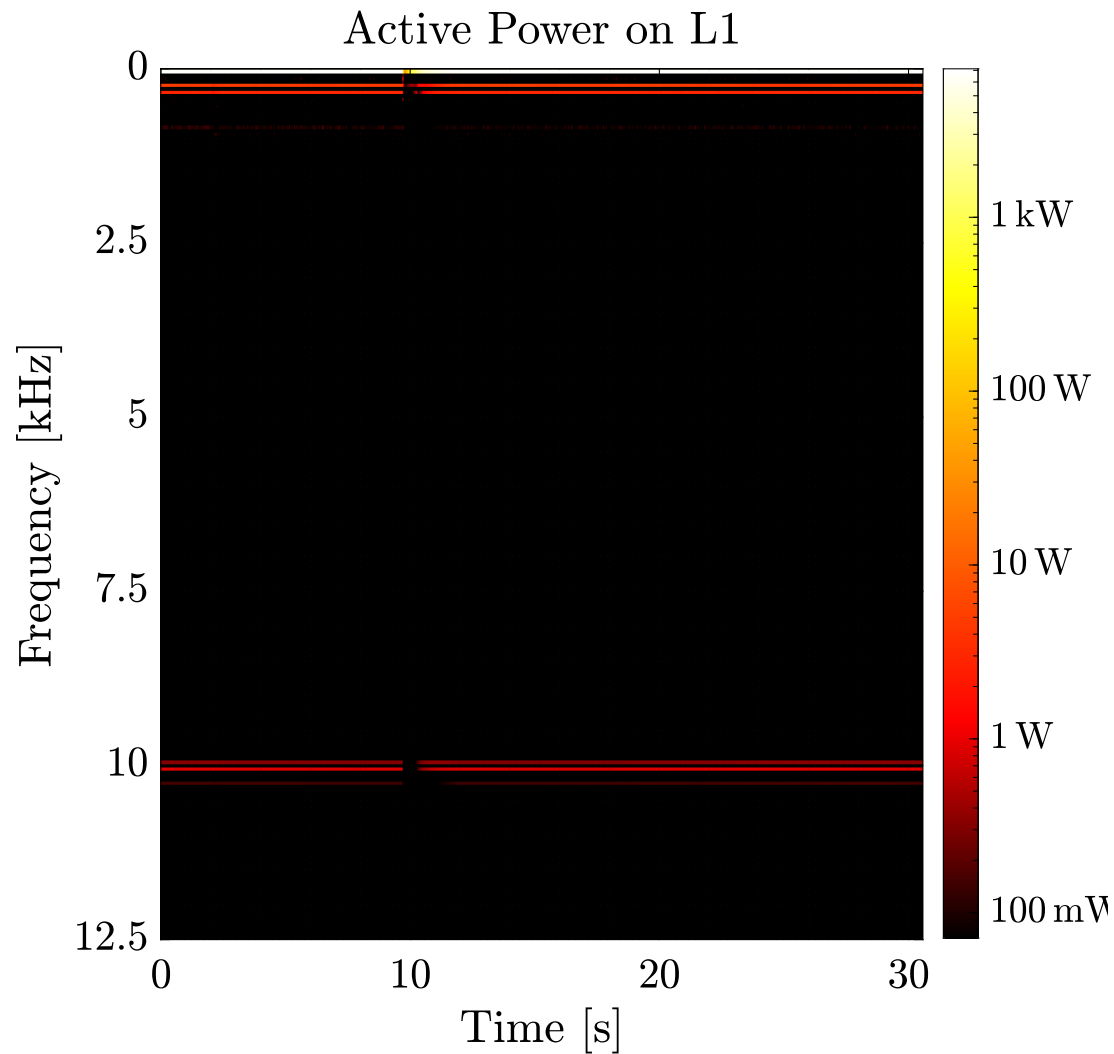



## Results: 1 EV Charging, Measured in LV Distribution Room

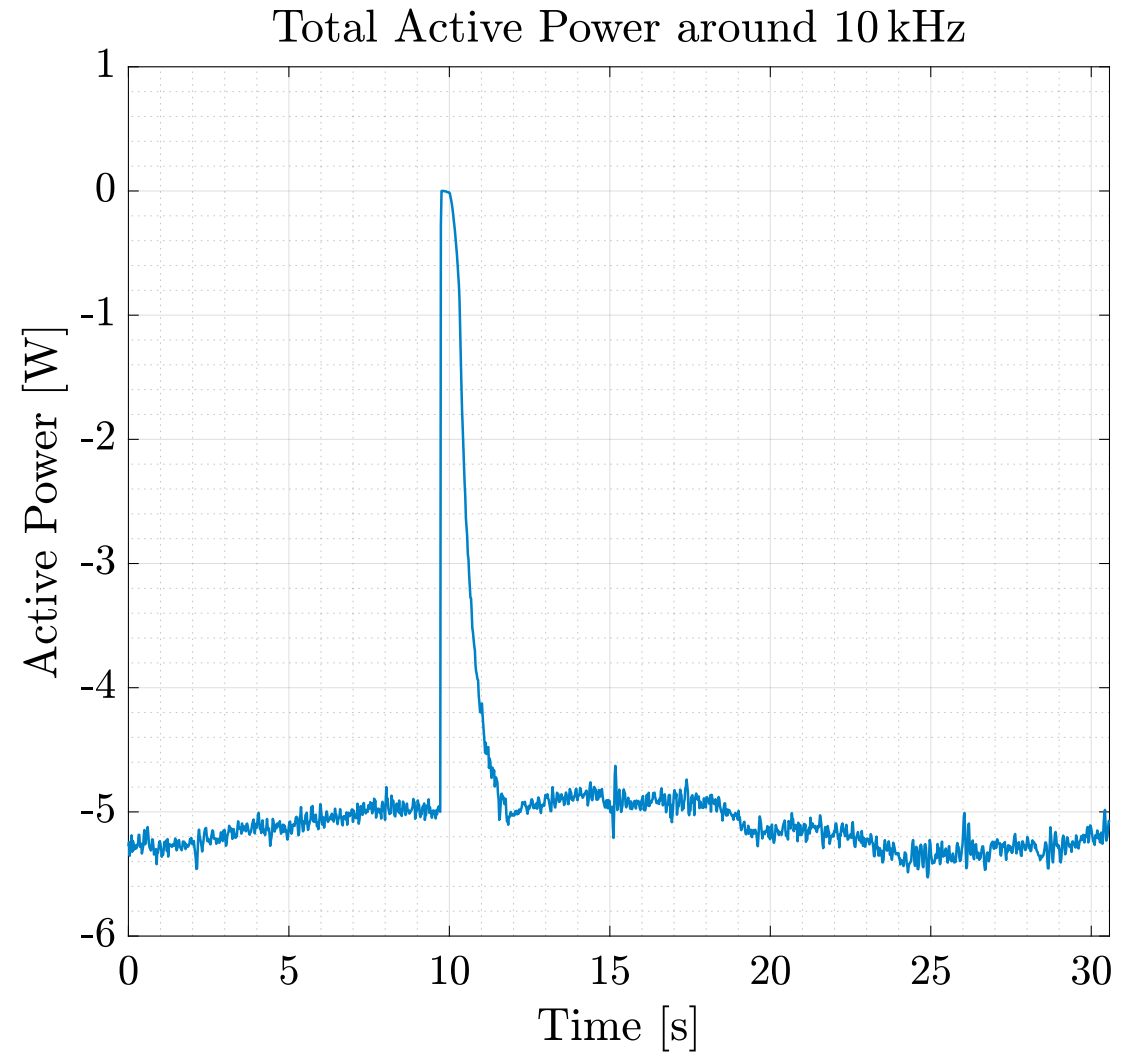
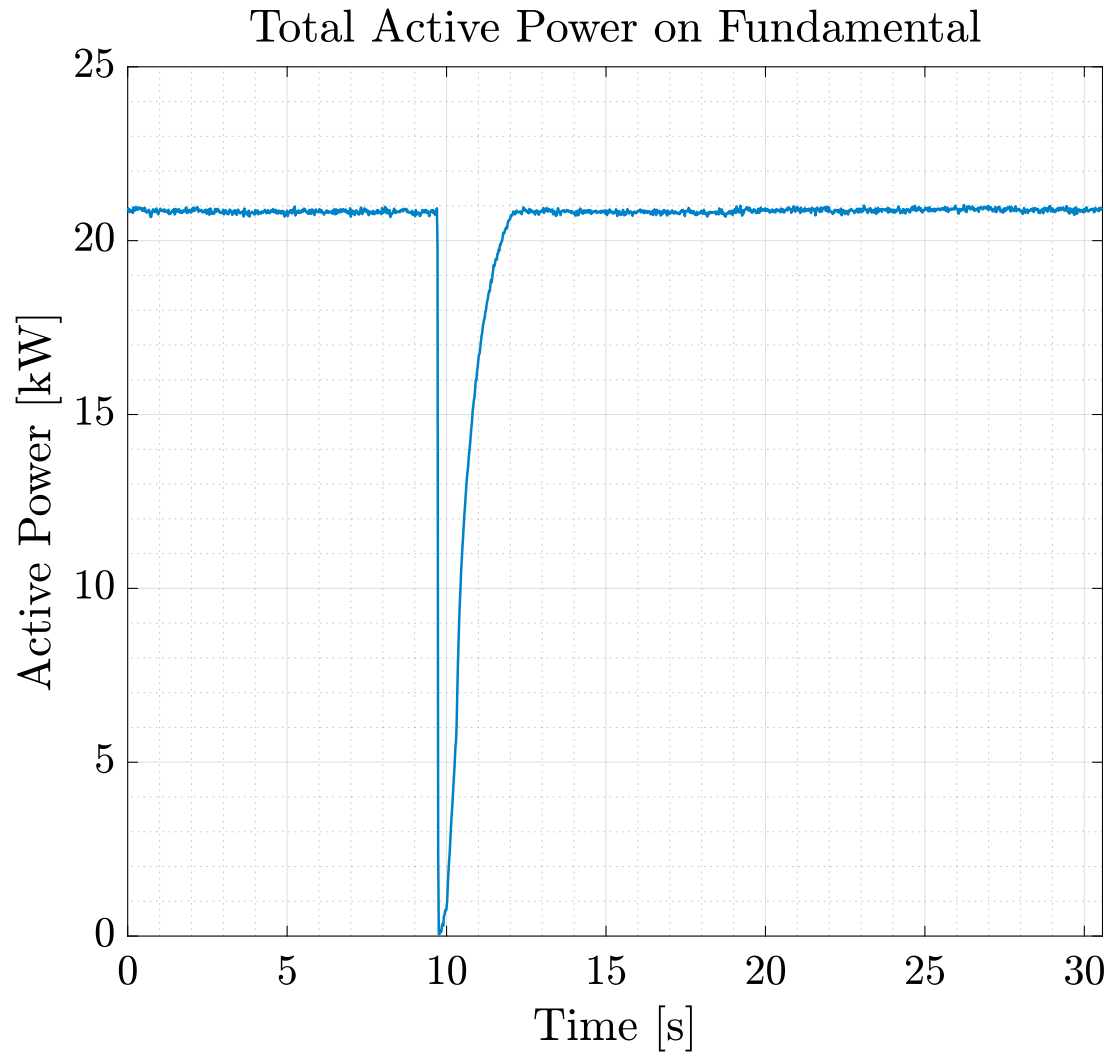

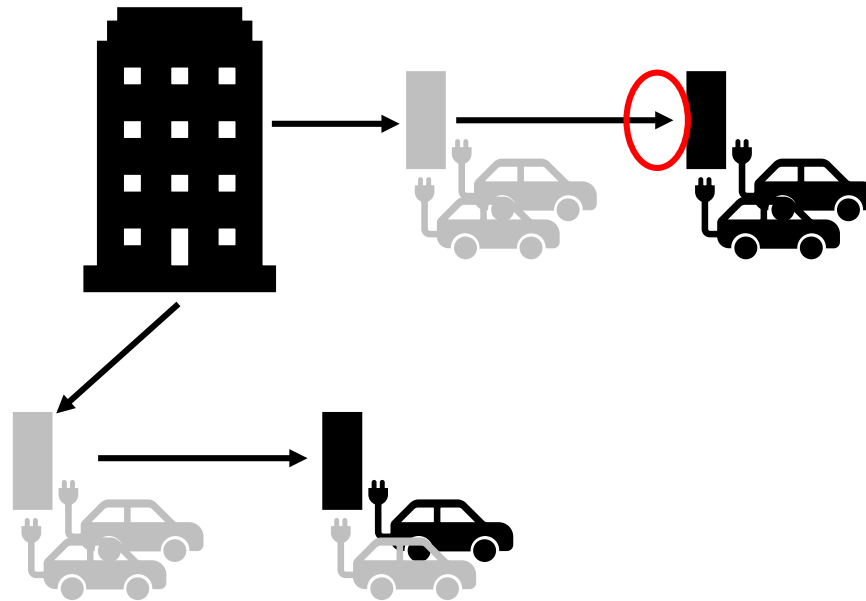

# Results: 2+1 EV Charging

Measured at Charging Station

# Results: 2+1 EV Charging, Measured at Charging Station

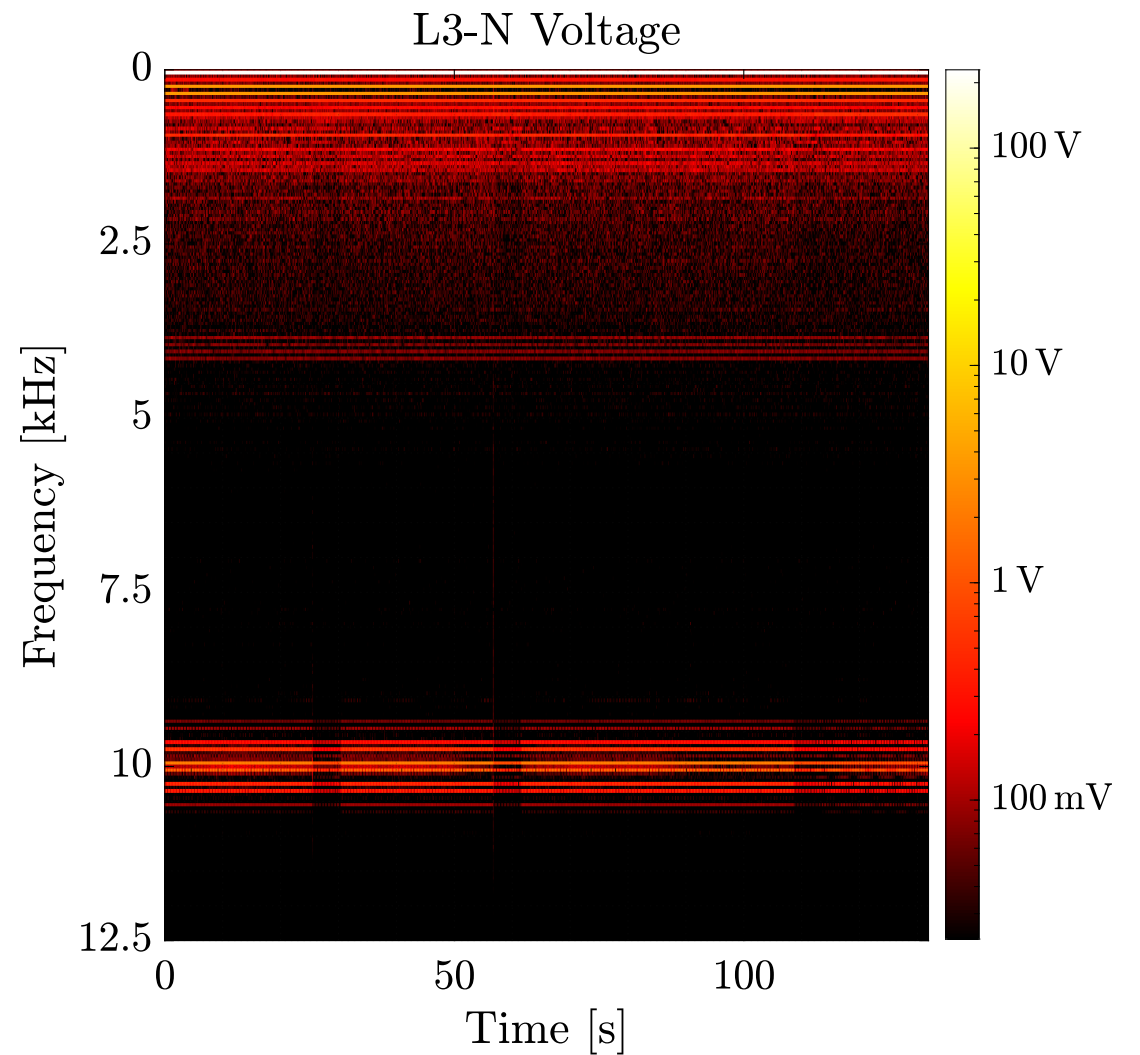
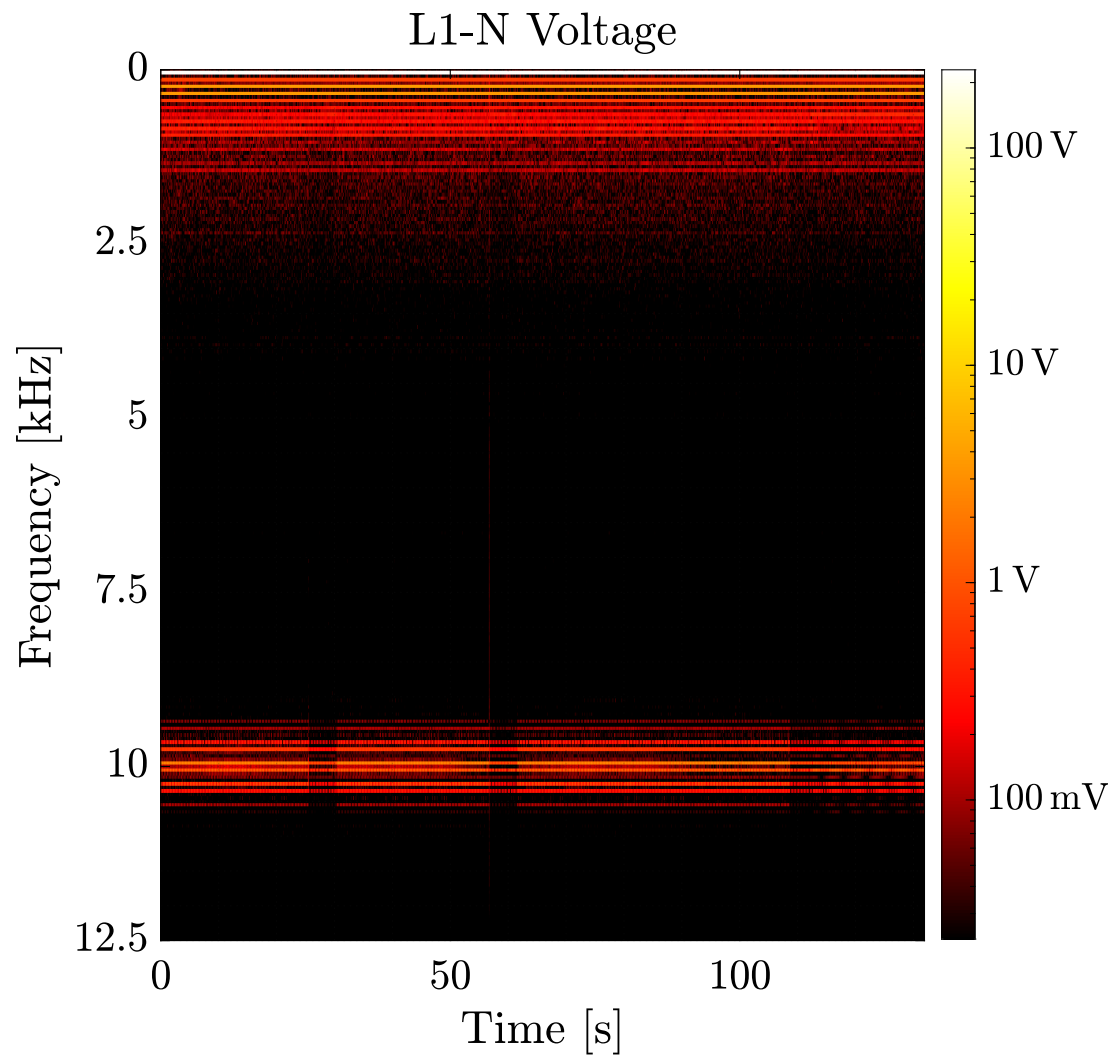

# Results: 2+1 EV Charging, Measured at Charging Station

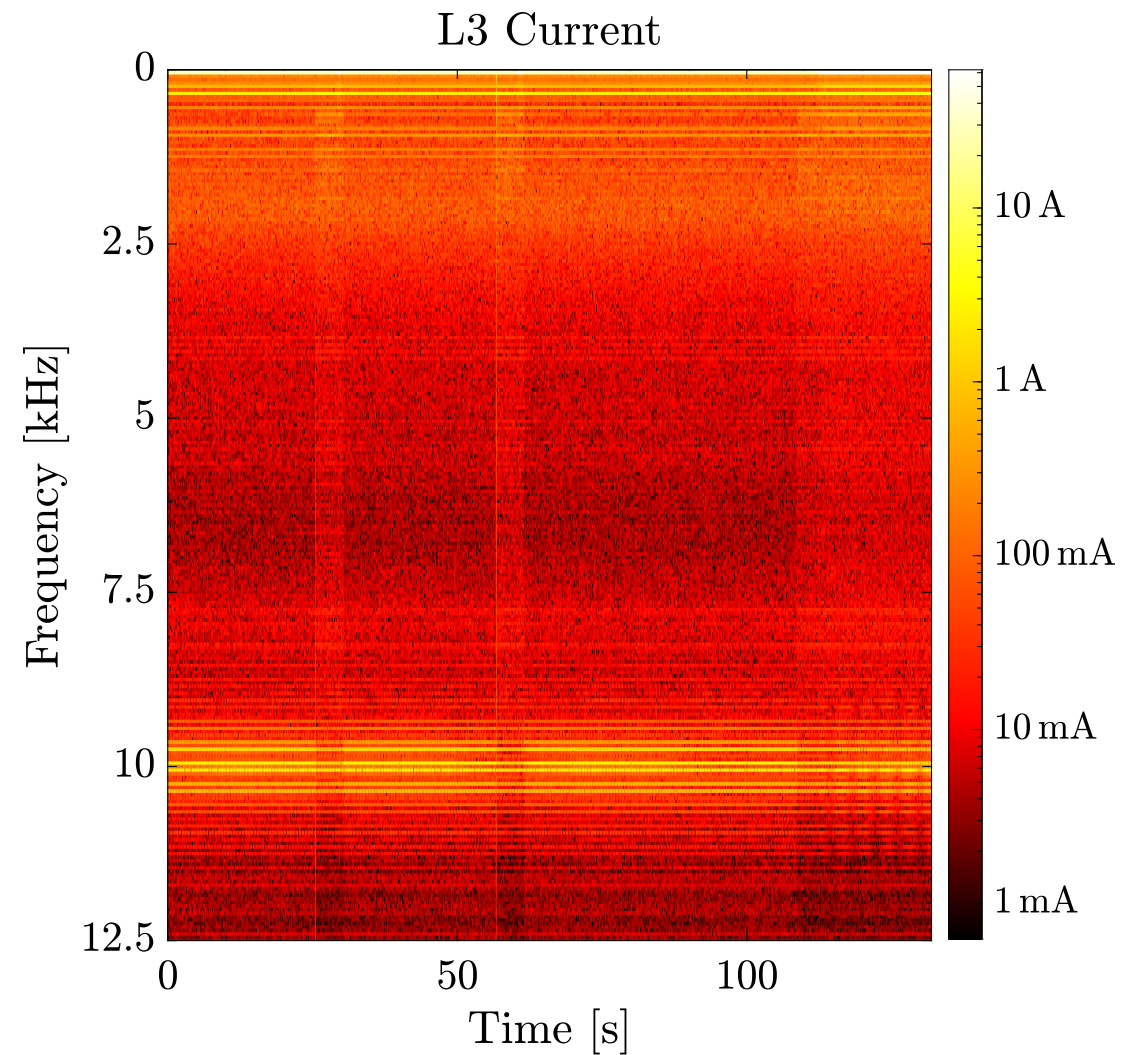
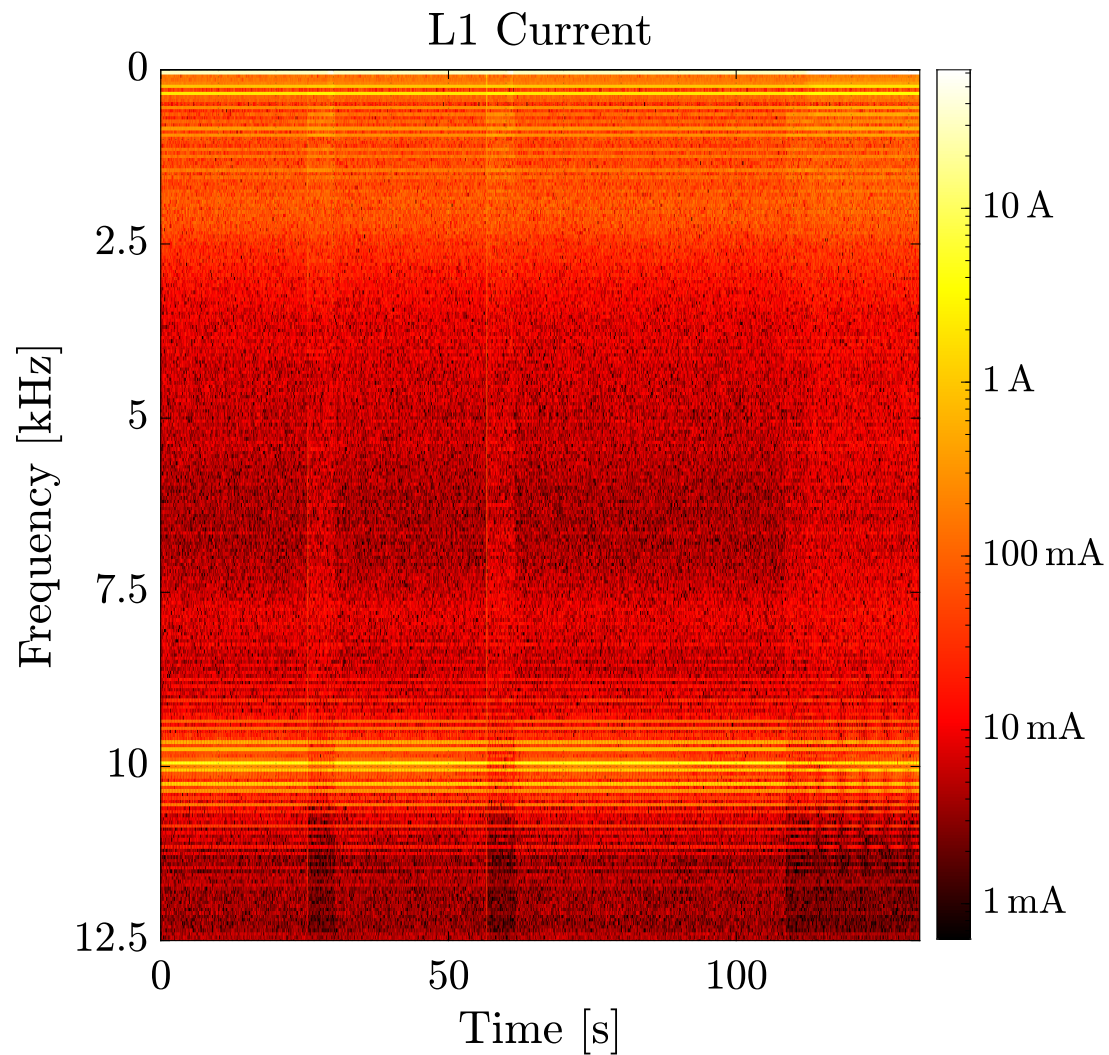

# Results: 2+1 EV Charging, Measured at Charging Station

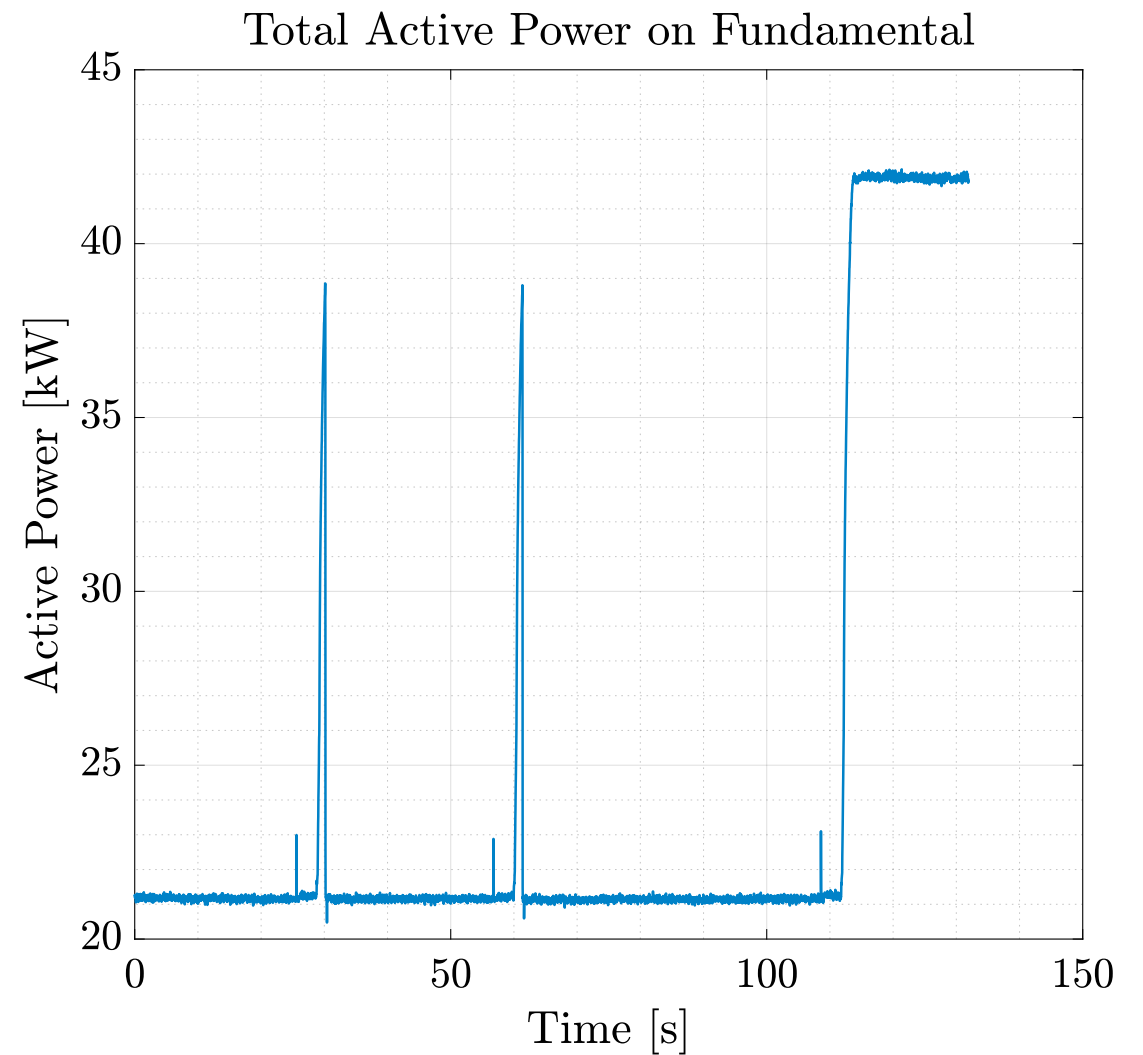
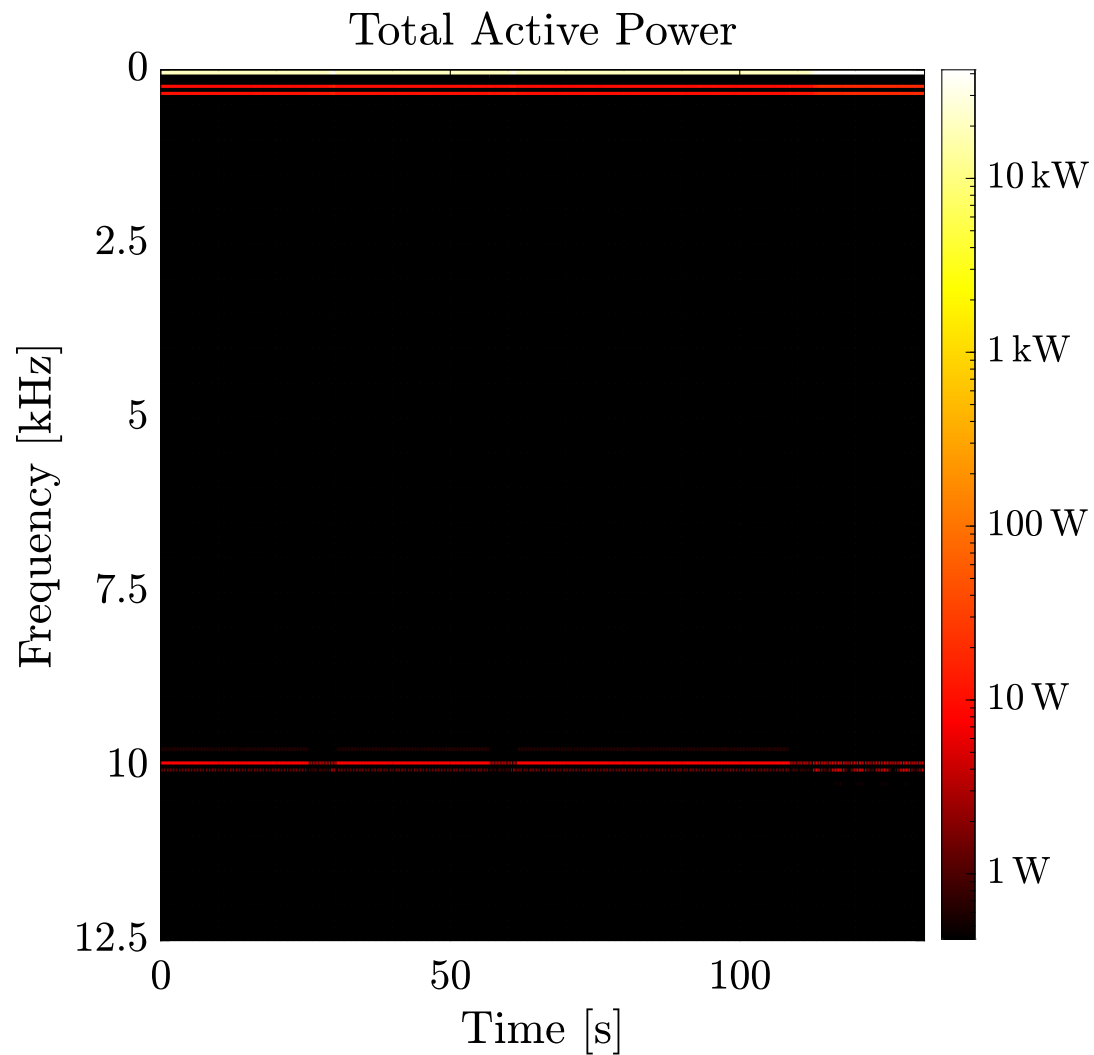

# Results: 2+1 EV Charging, Measured at Charging Station

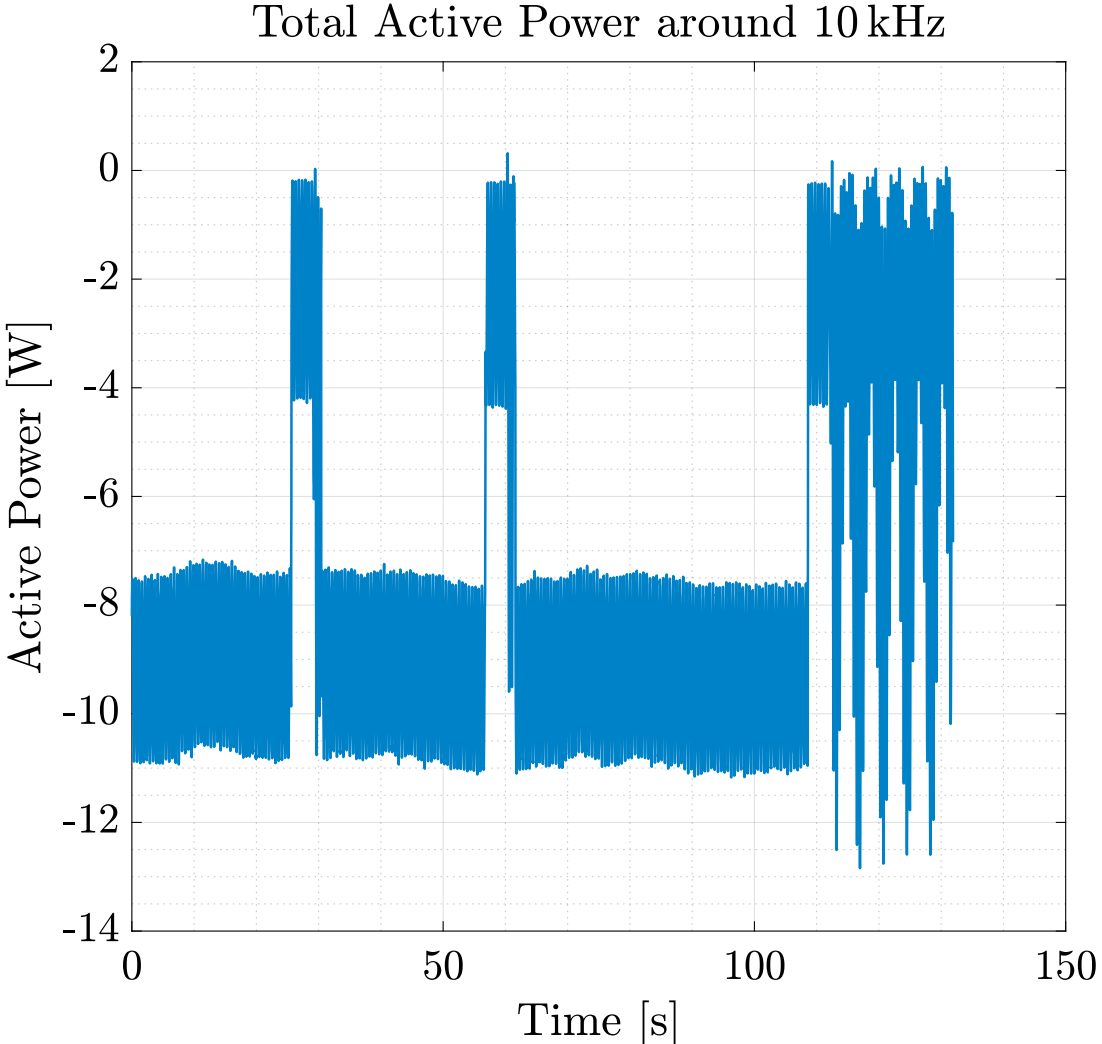

# Results: 2+1 EV Charging, Measured at Charging Station

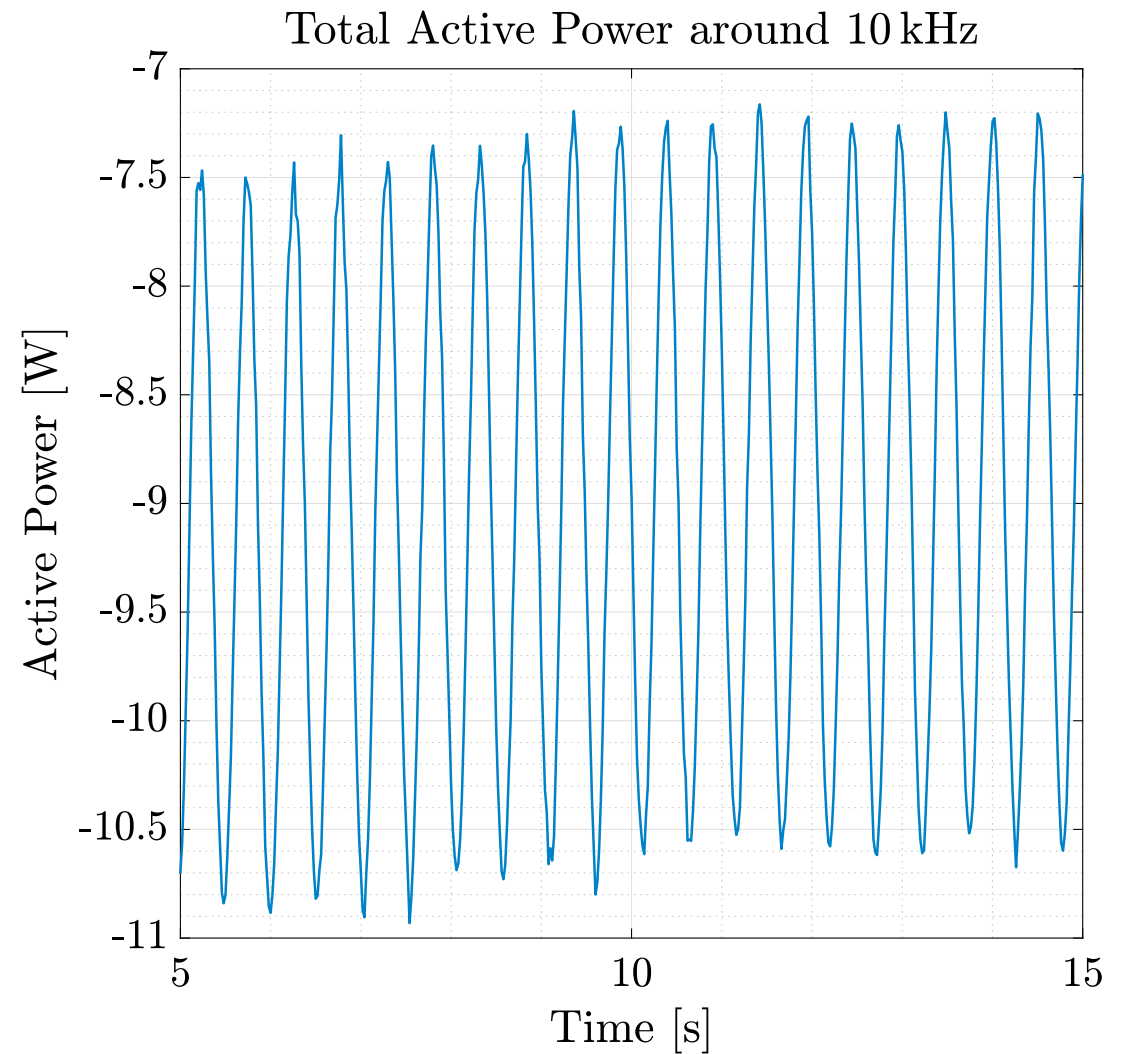
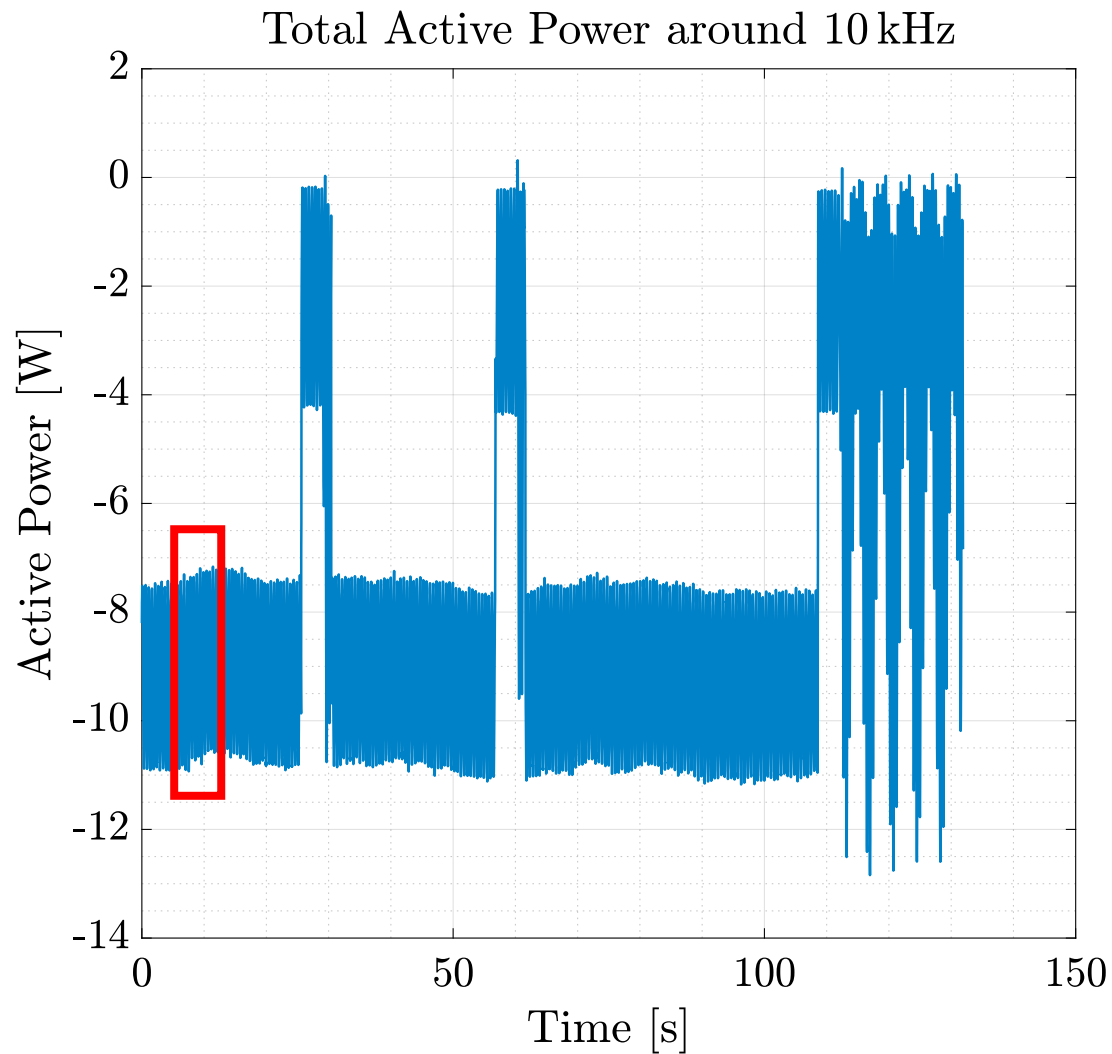

# Results: 2+1 EV Charging, Measured at Charging Station

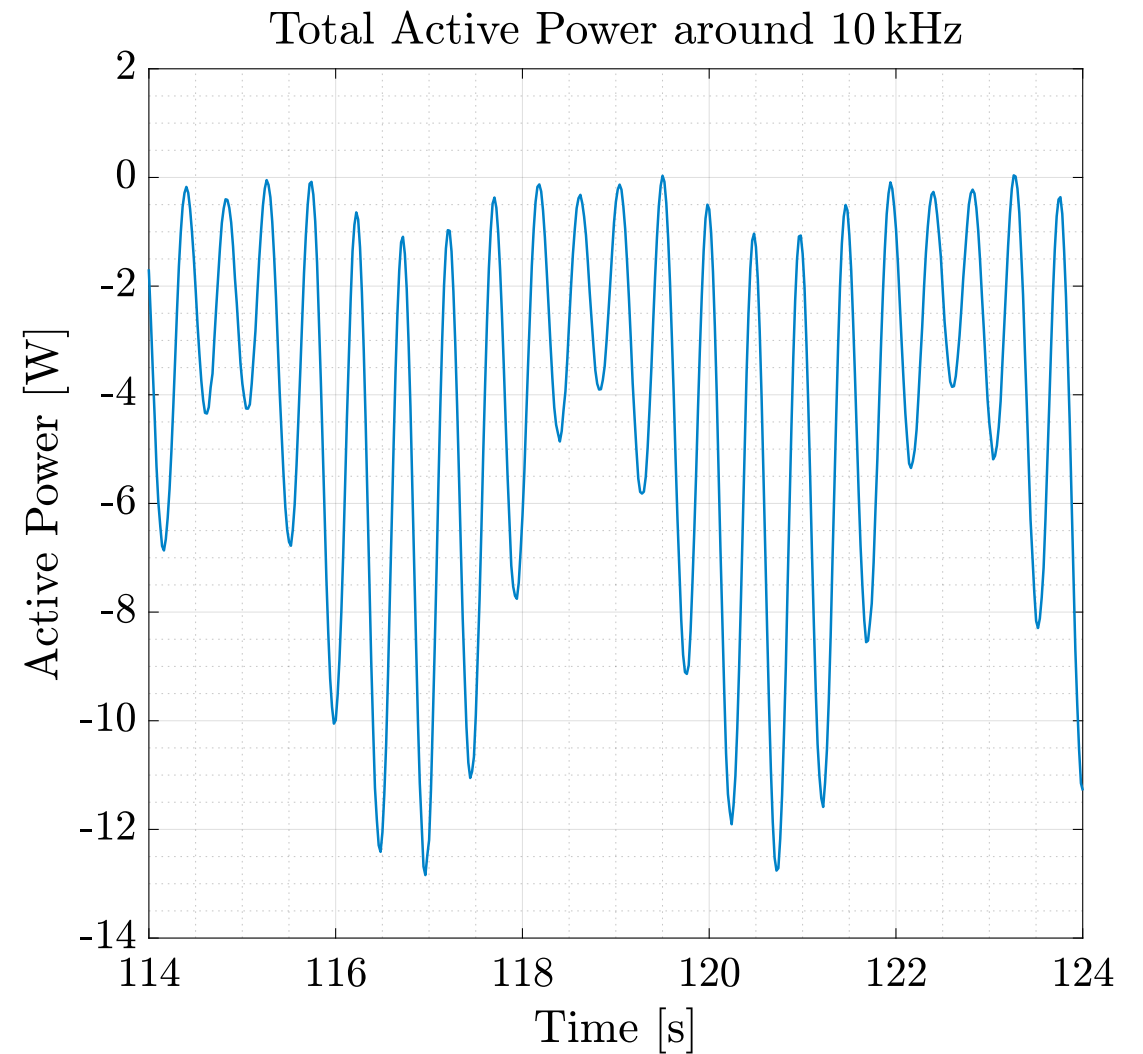
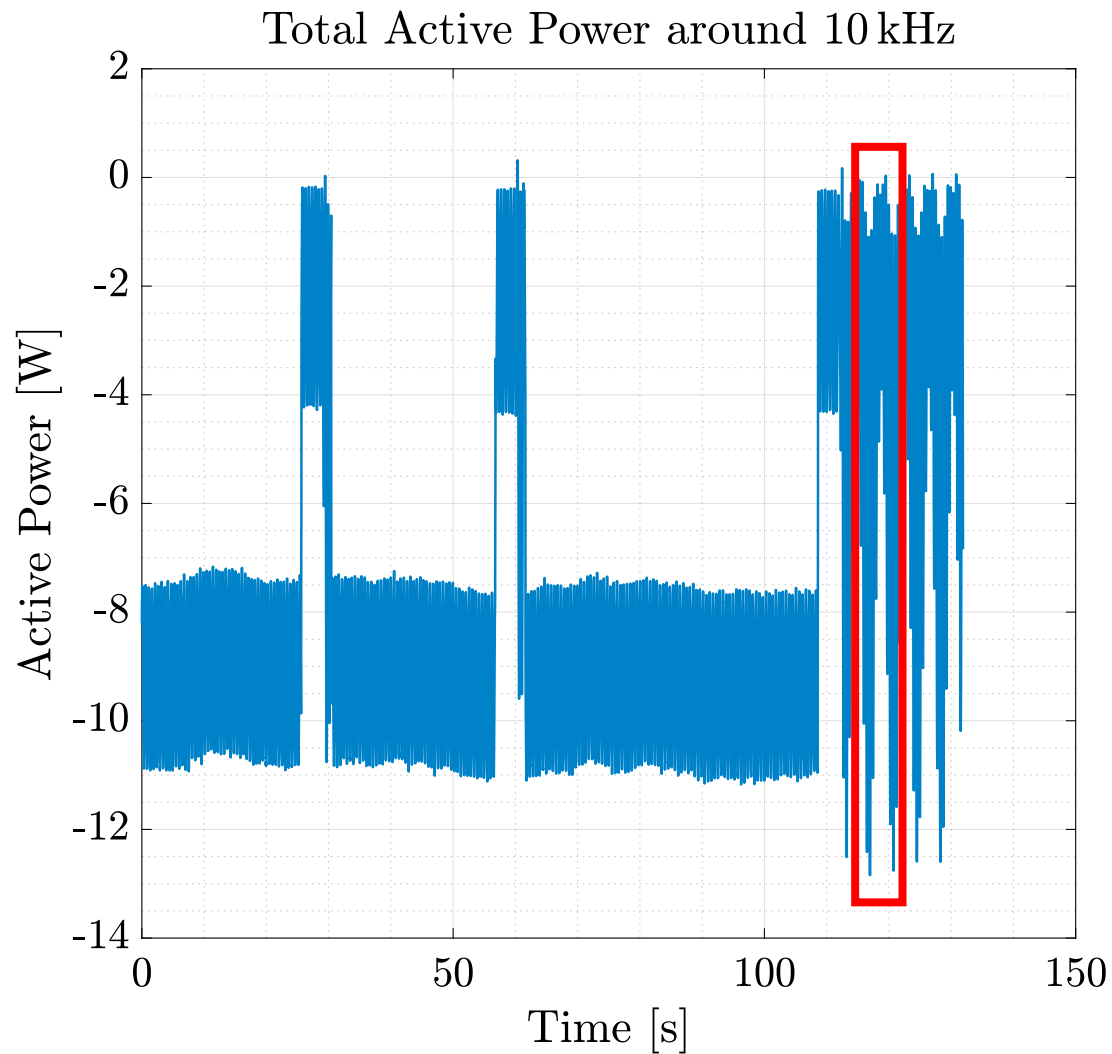



# Conclusions

- EVs are cause of the disturbances
- PQ disturbances are cause of the noise immissions
- Charging stations themselves are not part of the problem

## References

- J.-P. Kitzig and G. Bumiller, "Fast-Decaying Sine Ramp Windows for Signals With Limited Frequency Resolution," in *IEEE Transactions on Instrumentation and Measurement*, vol. 70, pp. 1-13, 2021, Art no. 6504813.
- J.-P. Kitzig, S. Schlaghecke, and G. Bumiller, "Power Quality Measurement System With PMU Functionality Based on Interpolated Sampling," *IEEE Transactions on Instrumentation and Measurement*, vol. 68, no. 4, pp. 1014–1025, 2019.
- J.-P. Kitzig, S. Schlaghecke, and G. Bumiller, "Accuracy of Power Quality Measurement Based on Interpolated Sampling," in *2018 IEEE PES Innovative Smart Grid Technologies Conference Europe (ISGT-Europe)*, 2018, pp. 1–6.
- J.-P. Kitzig and G. Bumiller, "Evaluation of Power Quality Measurement System Concept using an experimental setup," in *2019 IEEE International Instrumentation and Measurement Technology Conference (I2MTC)*, Auckland, New Zealand, May. 2019 - May. 2019, pp. 1–6.
- J.-P. Kitzig and G. Bumiller, "Proof of Concept for Three-Phase Extension of a Mains Frequency Estimation Algorithm," in *IEEE International Workshop on Applied Measurements for Power Systems: 2019 Workshop proceedings*, Aachen, Germany, 2019, pp. 1–6.
- J.-P. Kitzig, J. Paetzold, and G. Bumiller, "Power Quality Analysis in non-stationary mains frequency conditions," in *ETG-Fachbericht*, vol. 158, *Internationaler ETG-Kongress 2019: Das Gesamtsystem im Fokus der Energiewende : 8.-9. Mai 2019, Neckar-Forum, Esslingen am Neckar*, C. Rehtanz, Ed., Berlin: VDE Verlag GmbH, 2019.
- J.-P. Kitzig and G. Bumiller, "Timebase Offset Calibration of Analog-To-Digital Converters for Mains Frequency Measurement," in *3rd International Colloquium on Intelligent Grid Metrology (SMAGRIMET 2020)*, 2020.
- C. Nieß, J.-P. Kitzig, and G. Bumiller, "Phasor Based Zero Crossing Detection of the Mains Fundamental," in *3rd International Colloquium on Intelligent Grid Metrology (SMAGRIMET 2020)*, 2020.
- C. Nieß, J.-P. Kitzig, and G. Bumiller, "Measurement System for Time Variable Subcycle Impedance on Power Lines," in *2021 IEEE International Instrumentation and Measurement Technology Conference (I2MTC)*, Virtual Conference, May 2021, pp. 1-6.

Thank you  
for your attention!

Interessenverband  
Netzimpedanz



2021

jan-philipp.kitzig@hs-ruhrwest.de  
gerd.bumiller@hs-ruhrwest.de